



ACO Solutions for Residential Buildings

Helping to create safe and sustainable residential projects



Helping to create safe and sustainable residential projects







	ACO Group		4
	How can ACO Group help?	innovative solutions and expert support	6
	Roof, terrace and façade	challenges, standards, solutions	10
1	ACO Profiline	Stainless steel or galvanized steel drains	14
	ACO Profiline X	PP-GF drains	18
	ACO Spin	Gravity roof drainage	22
	ACO Terrace Gully	Direct floor drains for balconies and terraces	26
	ACO GM-X	Drainpipes	30
	ACO Roofblox	Roof rainwater retention system	34
	Infrastructure	challenges, standards, solutions	38
2	ACO DRAIN® Multiline Seal In	Watertight line drainage	42
	ACO KerbDrain	Kerbs with integrated drainage	48
	ACO Combipoint	Street drains with high hydraulic capacity	52
	ACO Multitop Bituplan	Self-leveling manhole covers	56
	ACO Stormbrixx SD	Rainwater retention and infiltration system	60
	Cellar	challenges, standards, solutions	64
3	ACO Therm Lightshaft system	English courtyard style light shafts with thermal insulation panel	68
	ACO Triplex / ACO Quatrix K	Backflow preventers	72
	ACO MultiMax	Grey/black water pump station for below ground installation	76
	ACO MultiStar DDP	Freestanding black water pump station	76
	Underground parking	challenges, standards, solutions	80
4	ACO DRAIN® Deckline P	Polymer line drainage for parking decks	84
	ACO XtraDrain	Stable MDPE line drainage channels	88
	ACO Parkdeck gully	Point drainage for multistory parking garages	92
	ACO Oleolift P	Freestanding oil separator with integrated pumping system	96
	ACO Oleopator G	Compact built-in oil separator	100
	Bath and spa area	challenges, standards, solutions	104
5	ACO ShowerDrain E+	Electropolished stainless steel shower channels	108
	ACO ShowerDrain S+	Shower channels for quick and easy installation	112
	ACO ShowerDrain C	Functionally designed shower channels	116
	ACO ShowerDrain Flex	Custom length shower channels	120
	ACO Slot 8	Stainless steel slotted drain	124
	ACO Easy Flow	Point drainage for bathrooms	128
	ACO Bath Gully MG	Shallow installed point drainage for the bathroom	131
	ACO ShowerStep	Designer slope profiles for bathrooms	132
	Open areas	challenges, standards, solutions	136
6	ACO Self® Euroline	Polymer concrete drainage channels	140
	ACO Self® Board & Gravel	Grass and gravel stabilisation systems	144
	ACO Vario	Indoor and outdoor grate mats for entrances	148
	ACO Self® Xtra Point	Point drainage gullies for houseyards	152
	ACO Uniface Covers	Access covers with embedding of flooring	156

ACO. we care for water

ACO is a water-tech company dedicated to protecting water. Based on our global drainage expertise, which protects people from water, we increasingly see our mission in protecting water from people as well. With the ACO WaterCycle, ACO supplies systems with which water can be collected and routed, cleaned, stored and finally reused. In this way, ACO contributes to the preservation of clean groundwater as a vital resource and makes a contribution to the world of tomorrow. In its Agenda 2030, the UN world community has defined the improvement of water quality as one of 17 goals for sustainable development. ACO's goal is to be an innovative partner for all who build the future.

In partnership with our clients, ACO meets the needs of tomorrow, and we are prepared to be first to offer a marketplace solution. Partnering with ACO means working with an innovation leader.

We anticipate global trends that require innovative solutions:

- Increasing urbanization: people are increasingly concentrating in large cities, and that leads to more and more dense and impermeable pavements and surfaces. As a result, the requirements for surface water management are growing worldwide
- Climate change: heavy rainfall will occur more frequently, causing widespread floodings
- Environmental pollution: increased environmental pollution also leads to significant pollution of surface waters and, therefore, of groundwaters as well. Drinking water supplies are at risk in some parts of the world. This leads to increased awareness of the problem and results in stricter legal requirements.





5.400

Employees in more than 44 countries around the world (Europe, North and South America, Asia, Australia, Africa)

35

Factories facilities in 18 countries



ACO Group's headquarters
Rendsburg /Büdelndorf, Germany



ACO Academy

Hans-Julius and Iver Alman
ACO Group's managing directors

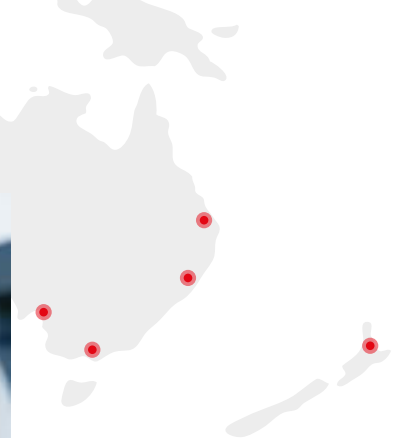



How can ACO Group help?

ACO is an innovation driver in all areas of modern surface water management.

The variety of solutions for residential areas offered by ACO holds advantages for investors, designers, and contractors, as well as for maintenance companies.

Our wide range of products provides solutions to all functional and aesthetic water management requirements inside and outside buildings in a residential development.

The ACO's engineering team takes an individual approach to projects and is available to assist at every stage of design, construction and maintenance.



ACO Academy

The ACO Academy's main goal is to serve as a resource and a platform for all participants in the investment and construction process.

Here, you can learn about the latest practices, projects, norms

and standards, both from our colleagues and from international experts. By creating an open door atmosphere, we encourage personal and group creative contacts and discussions so that together we can solve challenges, find new opportunities and

apply the latest innovations to the development of modern and secure residential projects.

ACO's services - another advantage for sustainable system solutions



Information and training

- Global trends
- Sustainable solutions
- Innovations
- Product training
- European standards
- Local regulations



Design and optimisation

- System solutions
- Product and installation details
- Hydraulic and static calculations
- Specifications
- Value engineering
- European standards and local regulations



On-site support

- Project supervision
- Installation training
- Installation instructions
- Technical documentation



Monitoring and service

- Project supervision
- Maintenance training
- Maintenance instructions
- Commissioning and service
- Warranty Service



1





Roof, terraces and façade

The roof, façade and terraces constitute a building's boundary surfaces. Their design is no less complex than that of a building's other components. Errors in roof design can be dangerous and can damage a building or impact the value of a property. In extreme cases, a building may collapse. Many factors, such as the local climate, regulations, and architectural and construction requirements, must be considered when designing these areas.

Challenges in the design, construction and maintenance of roofs, terraces and façades

1

Heavy rainfall

Flat roofs are a sensitive architectural area where professional drainage design is especially important. A flat surface creates conditions for rapid accumulation of large amounts of water. Modern climatic phenomena require an effective drainage system for building protection.



2

Barrier-free movement

Modern residential buildings must provide free access and unrestricted movement in all internal and external areas. The height of drains must be adjusted to within a millimeter of pavement level. At the same time, they must prevent water from accumulating and splashing during a heavy flood.



3

Fire protection

Every project must comply with local fire safety requirements. Roof installations must be designed, installed and maintained in such a way as to ensure the safety of a building's occupants in the event of fire or smoke.



European standards and regulations



According to Art. 93 of Ordinance **No. RD-02-20-2 dated 26/01/2021** for determining requirements for accessibility and universal design of the elements of an accessible environment in an urbanized area and of the buildings and facilities, 93. Open spaces in the buildings shall be dimensioned in compliance with the following requirements:

1. ... the threshold heights of terraces must not exceed 2 cm;

Application of the system
ACO Profiline allows completely threshold-free transition from the interior to terraces.

ACO System solution

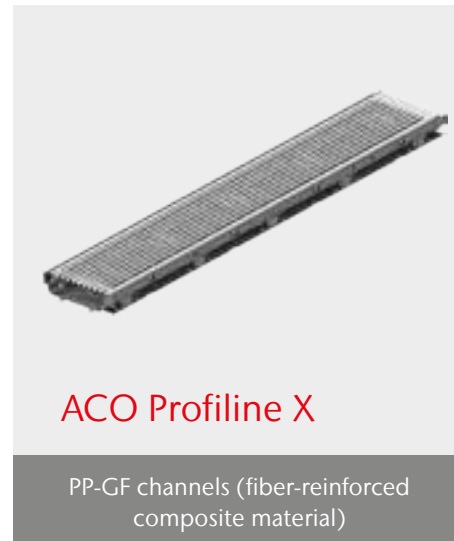





Roof, terraces and façade

ACO Profiline

Stainless steel or galvanized steel drains

ACO Profiline drainage channels provide a drainage system for vertical façades, as well as terraces, balconies, flat roofs, green roofs and roof gardens. They are the ideal solution, combining functionality and design. The system is an optimal solution for terraces with double flooring, spaced flooring, decking or terraces with a drainage layer. ACO Profiline collects surface water from a façade and drains it through the perforations in the channel - along the waterproofing membrane to a point trap in the discharge gully.

ACO Profiline

Product advantages

- Special designed for permeable / elevated floor systems
- Stainless steel or galvanized steel drains
- Wide selection of stainless or galvanized steel gratings
- Light weight for easy transport and installation
- Adjustable height from 55-168 mm
- Suitable for pedestrians and wheelchairs

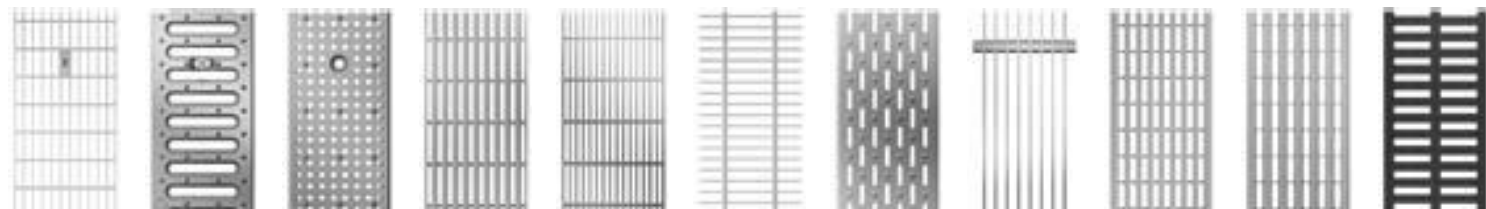
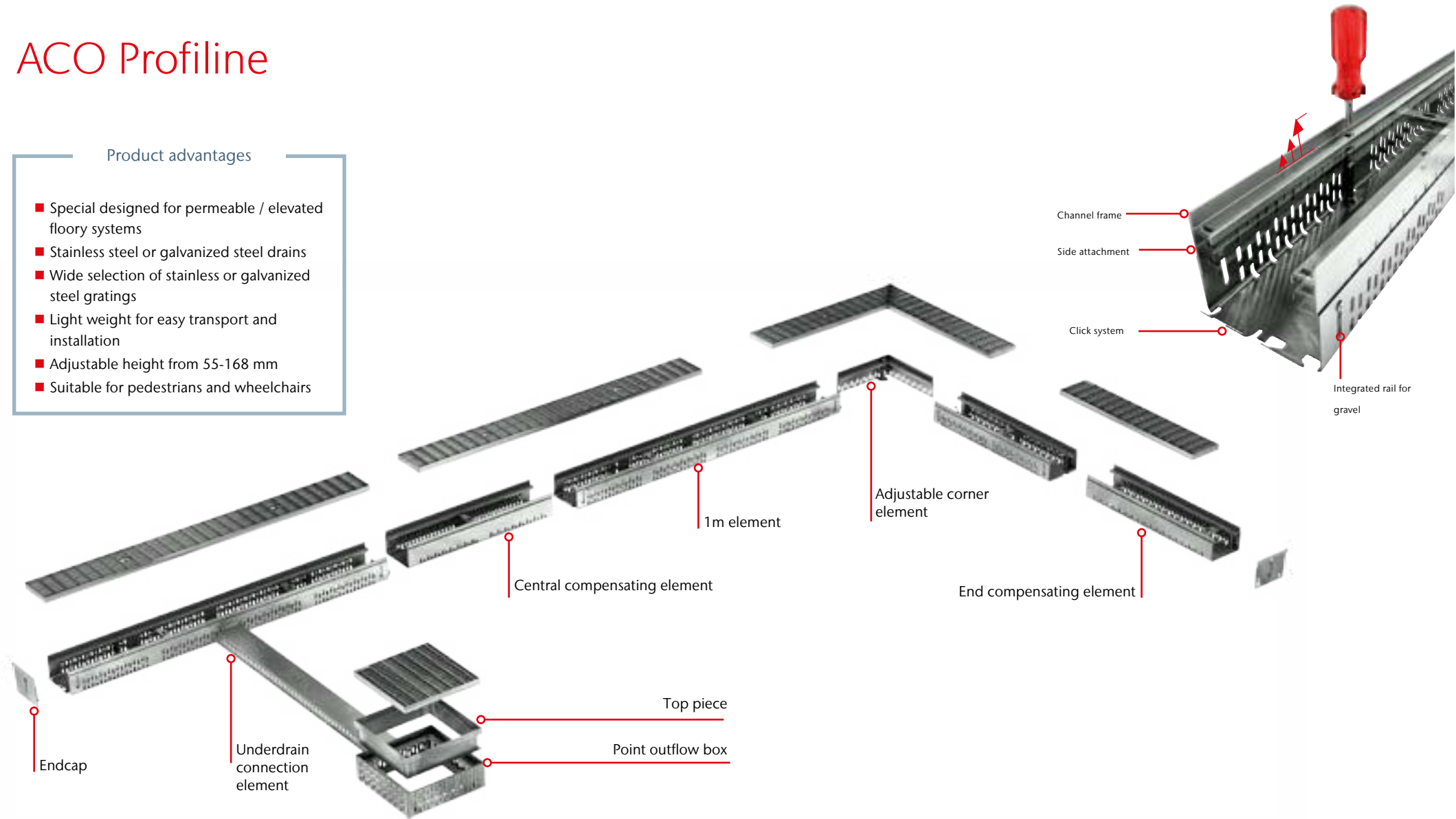

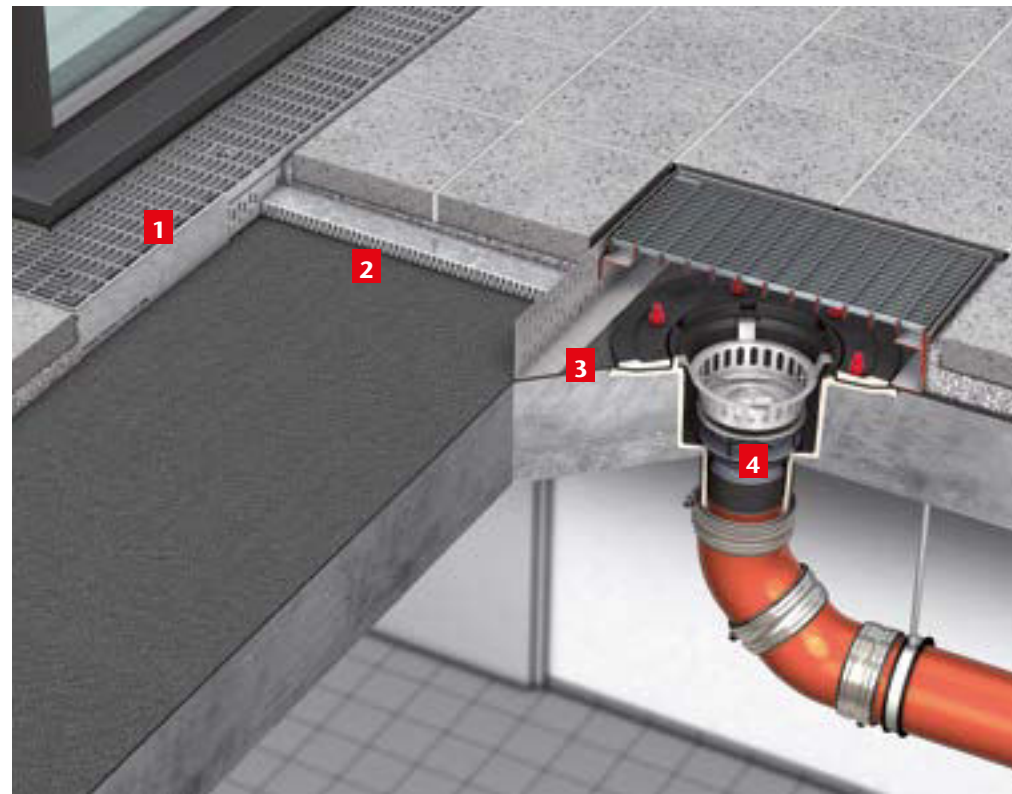

Diagram of drainage system in front of a terrace door

- 1 | Drainage channel
- 2 | Connection to dischargepoint
- 3 | Discharge box
- 4 | Roof gully





Roof, terraces and façade

ACO Profiline X

PP-GF channels (fiber-reinforced composite material)

Façade channels must be efficient and resistant to different climatic conditions while simultaneously presenting a good aesthetic appearance. In addition, builders need a cost-effective solution for their projects. The new ACO façade drainage system combines all these requirements in one solution. ACO Profiline X is an addition to the ACO Profiline system and is made of a fiberglass-reinforced corrosion-resistant material. The range of available gratings enhances a structure's aesthetic finish.

ACO Profiline X

Product advantages

- Special designed for permeable / elevated floory systems
- High stability thanks to fiberglass reinforcement (PP-GF)
- Easy to shorten (without danger of corrosion)
- Thermal expansion anticipated during preparation of the material
- Anthracite color with a discreet channel edge
- Good load distribution thanks to the large surface
- Quick and easy installation
- Convenience of transport and storage

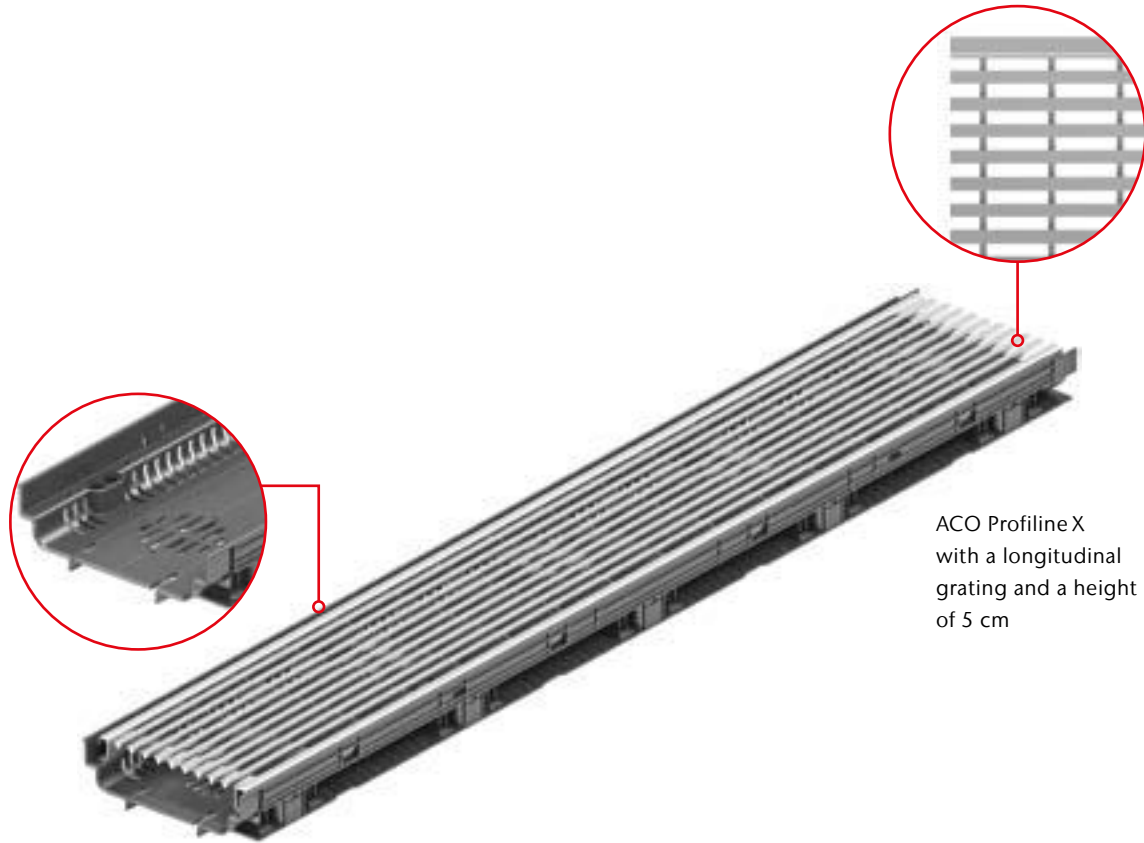

ACO Profiline X with a longitudinal grating and a height of 5 cm

Profiline X gratings



Mesh grating 30/10 with optimized locking



Grating with longitudinal openings



Grating with longitudinal bars

Construction height

ACO Profiline X has fixed construction heights of 5 and 7.5 cm. Construction width is 15.5 cm.

ACO Profiline X 5 cm

ACO Profiline X 7.5 cm





Stacking of ACO Profiline X
façade channels - easy and
convenient storage

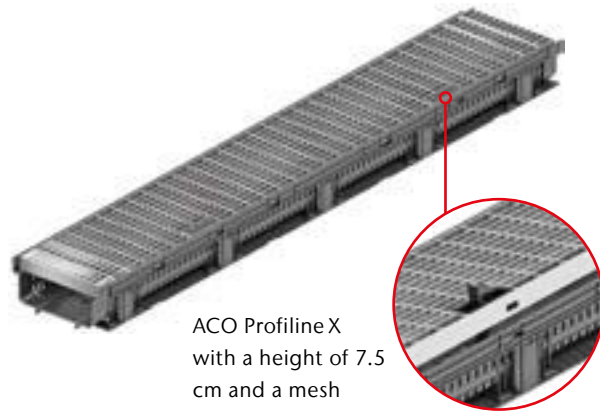

ACO Profiline X
with a height of 7.5
cm and a mesh
grating with
optimized locking

Optimized grating lock

The lock on the mesh grating has received special attention. Grating installation in the façade area is now even easier.

- The one-sided lock is discreetly integrated into the logo on the grating and has an integrated lifting function.
- optimized positioning of gratings using spacers

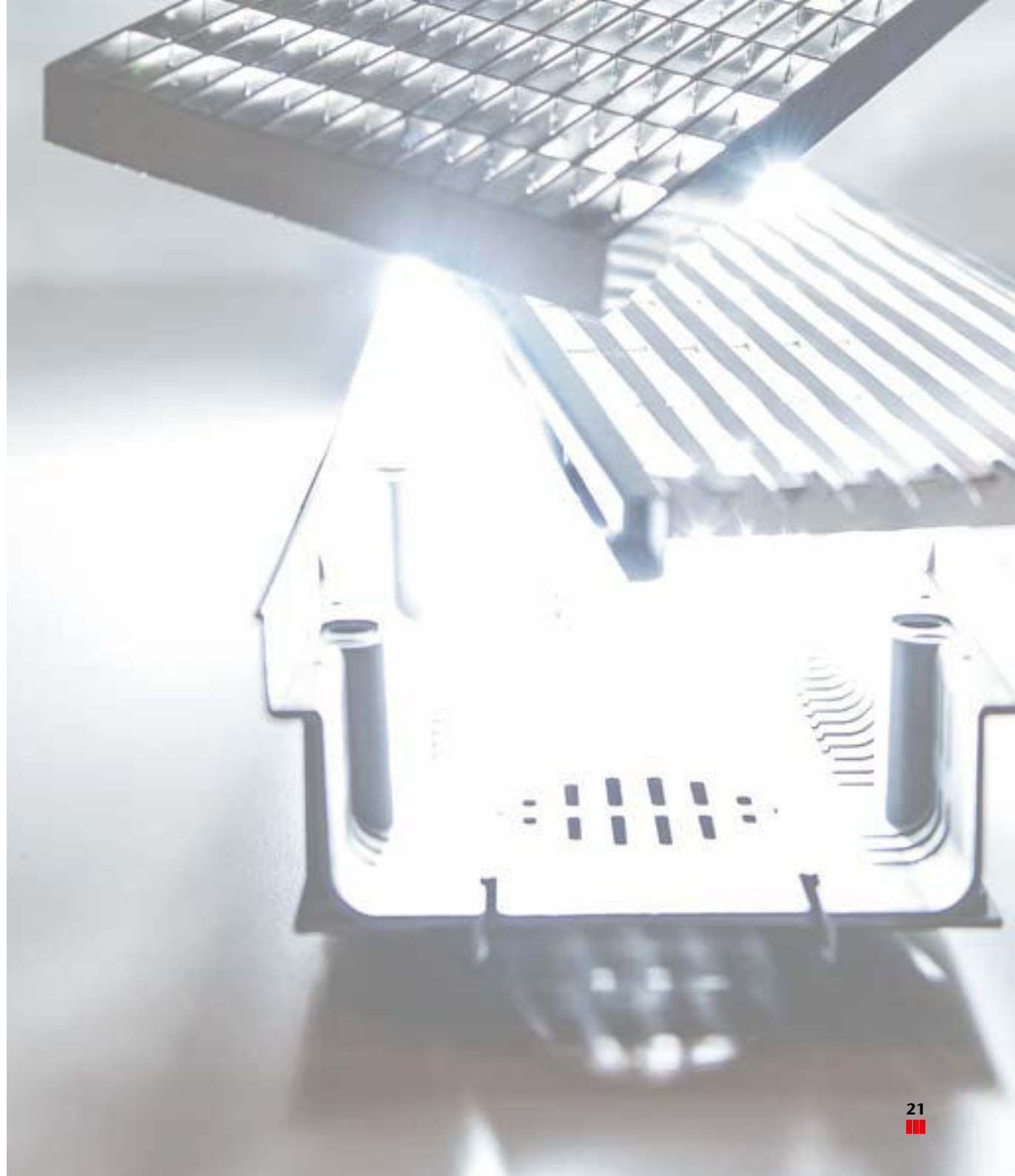





Roof, terraces and façade

ACO Spin

Gravity roof drainage for green roofs

Heavy rainfall on a flat roof can significantly increase the volume of rainwater. ACO offers functional solutions specifically focused on efficient drainage of flat roof surfaces. The use of gravity drainage systems is the appropriate solution for small roof surfaces.

ACO Spin

Product advantages

- Green roof gullies
- Made of stainless steel or cast iron.
- Small roof surfaces, up to 150 m² per roof water inlet
- Attic space not restricted
- Short horizontal outlet
- Full range of accessories: gratings, insulation bodies, heating elements

Cast iron drain bodies



Stainless steel drain bodies

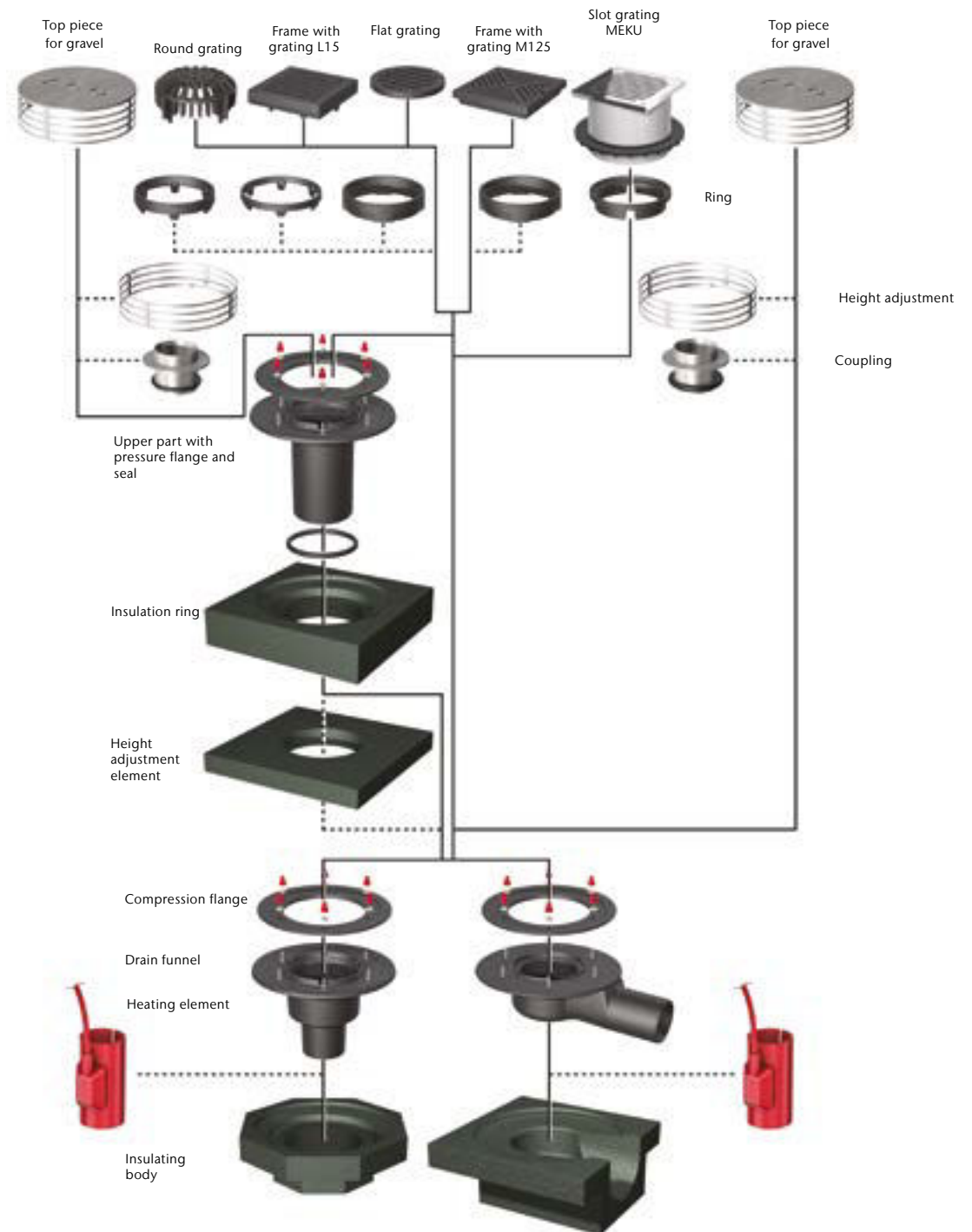

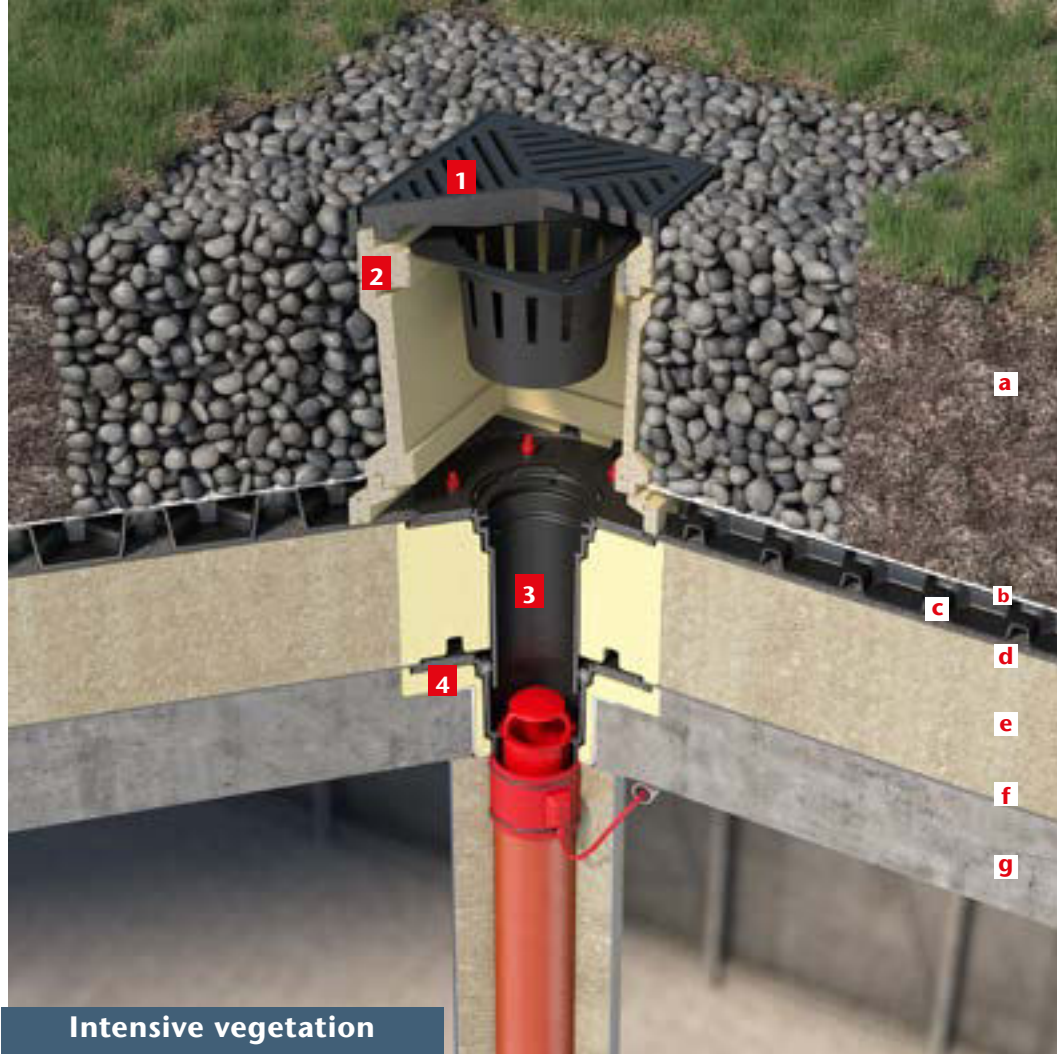

Intensive vegetation

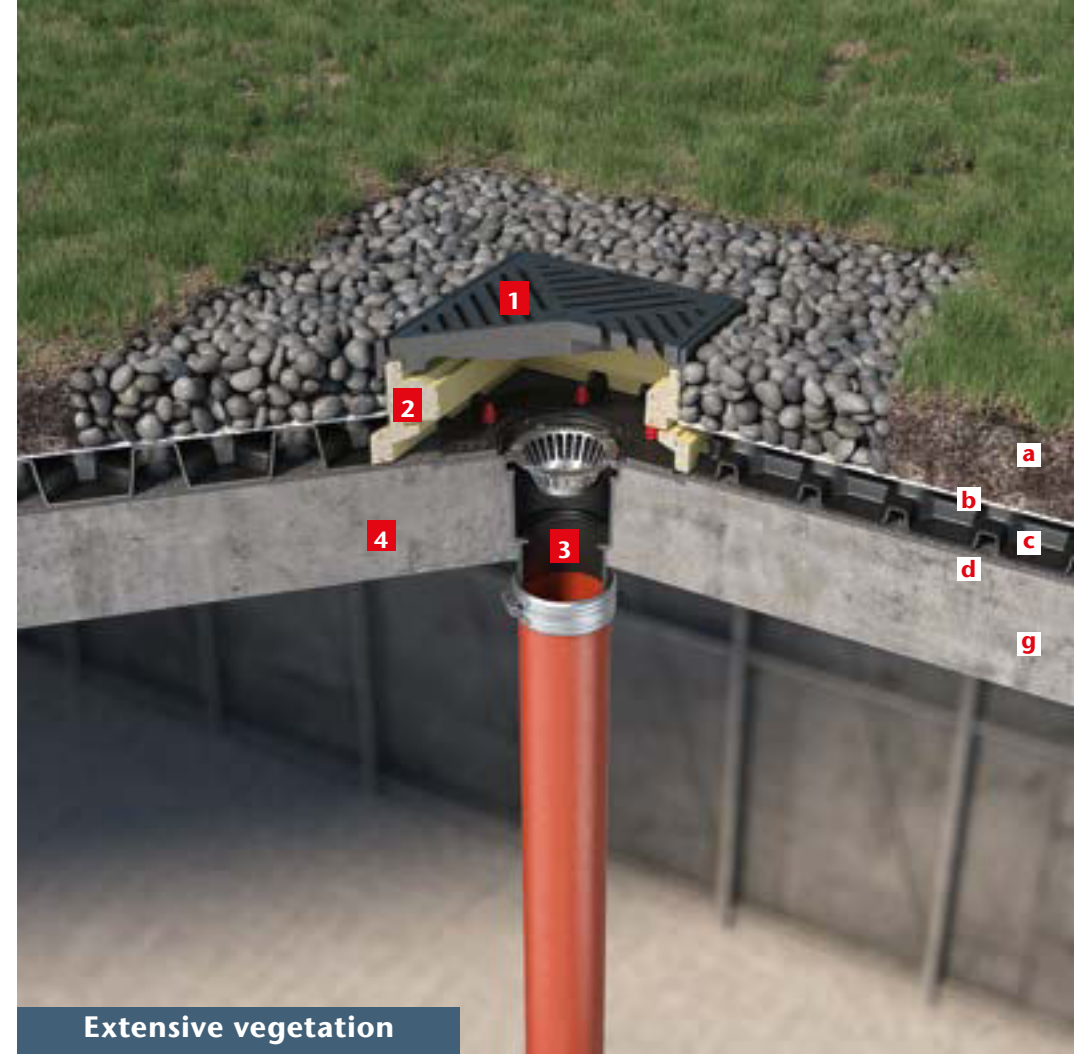

Extensive vegetation

- 1** Frame with cast iron grating
- 2** Intermediate element
- 3** Cast-iron roof drain
- 4** Thermal insulation body

- a** Soil
- b** Geotextile filter
- c** Drainage layer
- d** Waterproofing
- e** Thermal insulation
- f** Vapor barrier
- g** Concrete slab (per construction drawings)

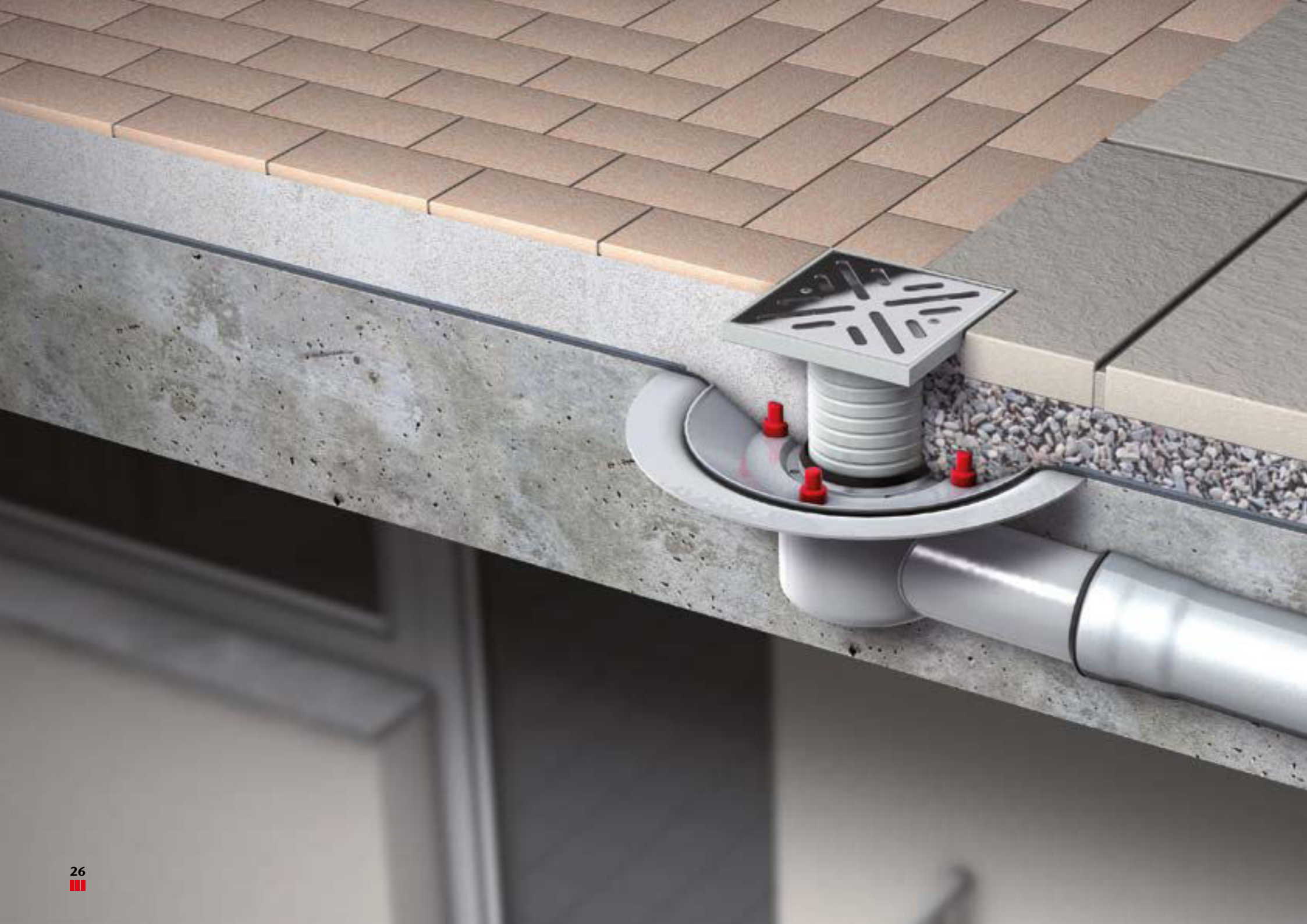



Roof, terraces and façade

ACO GM-X Gully

Point GM-X gullies for balconies and terraces

The new point drains for balconies and terraces with a compression/adhesive flange are modular and therefore ideally suited for a wide variety of installation situations - whether functional sealing of a terrace or design of a balcony floor structure with aesthetic integration of drain pipes.

The gullies are made of high-quality stainless steel (1.4301) and are therefore highly durable and strong.

ACO GM-X Gully

Product advantages

- Modular System
- Suitable for use with liquid waterproofing materials and bituminous waterproofing membranes
- The flange width of 100 mm complies with the requirements of EN 1253
- Available with variable flange for wall and corner wall, with a minimum distance to wall of 30 mm
- Can be used as a unitary or direct drain
- Small diameter Ø: DN 50 / DN 70 with 130 mm, DN 100 with 150 mm
- Made of corrosion-resistant 1.4301 stainless steel

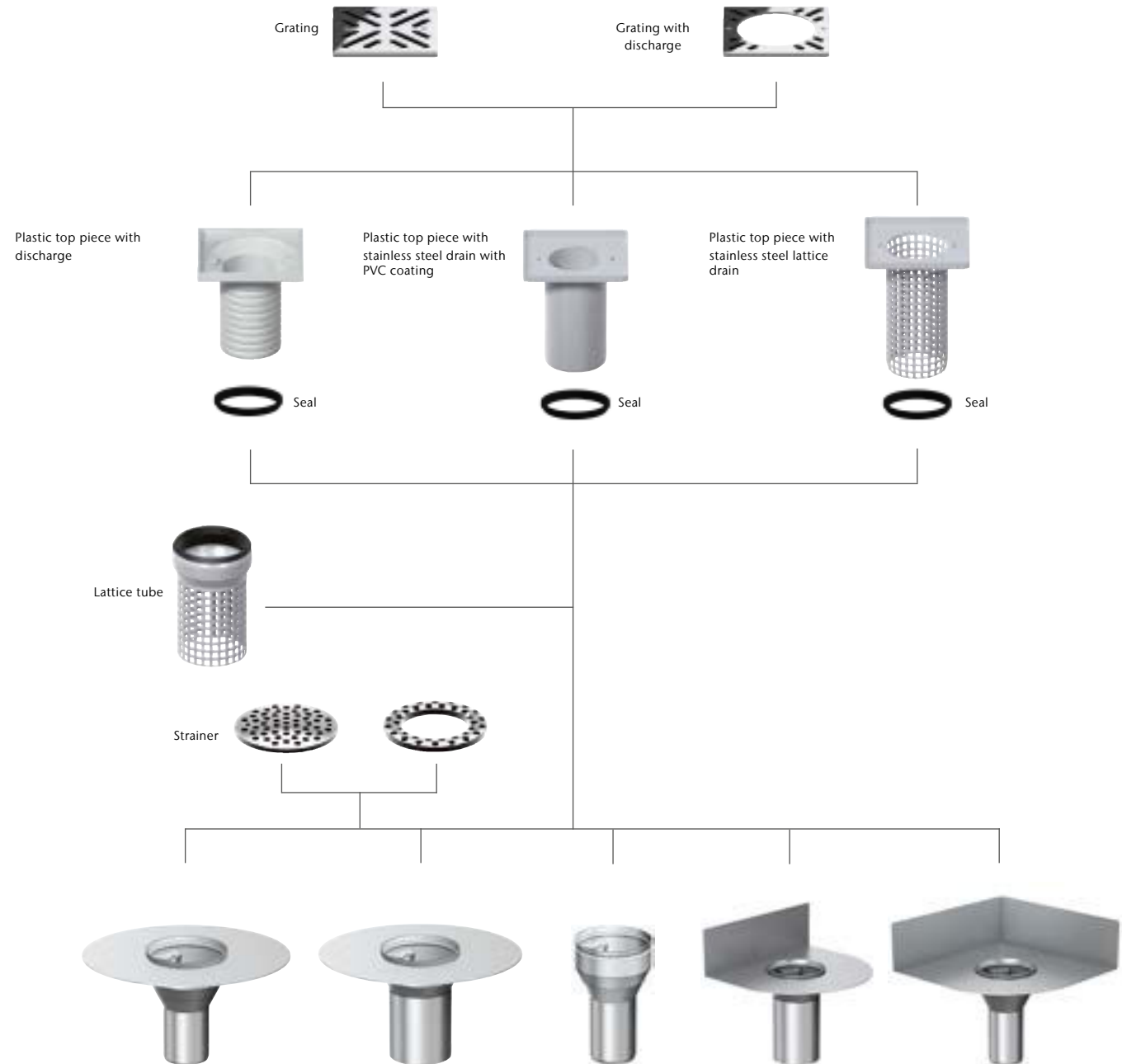



Balcony tiles on legs or gravel base



Balcony tiles sealed with self-leveling surface







Roof, terraces and façade

ACO GM-X Pipe

Galvanised steel drainpipes

ACO GM-X drain pipes made of welded precision steel pipe are used successfully in the field of flat roof drainage in the nominal sizes DN 32 - DN 300. The extensive range of pipes and fittings enables a quick and economical solution to any connection problem. All pipe parts and fittings are galvanized steel inside and out. The average zinc layer is shock and impact resistant. The zinc layer provides cathodic protection on the surfaces and thus prevents rusting underneath.

In addition, the pipe parts and fittings are coated on the inside with a plastic coating based on alkyd melamine resin. This inner coating of the pipe largely prevents incrustation. Optimum corrosion protection is achieved together with the zinc layer. Both the hot-dip galvanizing and the additional internal coating meet the requirements of EN 1123-1

ACO GM-X

Product advantages

- Made of steel galvanized pipes and fittings
- According to EN 1123
- Suitable for balcony and patio drains made of stainless steel
- Additional internal coating based on alkyd melamine resin
- Variety of pipe parts and fittings available
- Individual color design in RAL colors through powder coating possible on request
- Accessories: rubber seal

Resistance to changing weather conditions

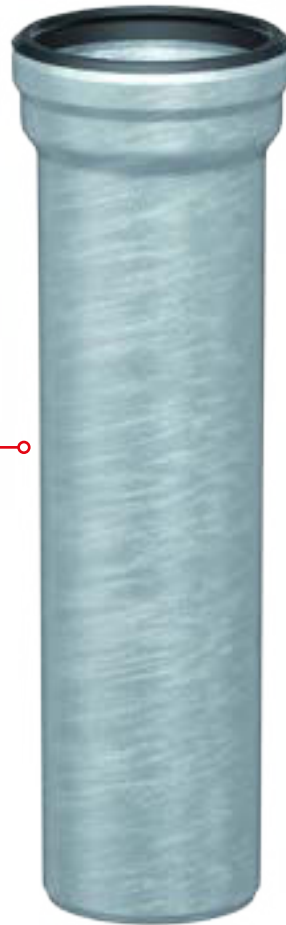

rubber seal



Fire protection consistent with the highest class A1 noncombustible materials



push socket 1 A



single branches



double corner branches



S-bend foul air traps

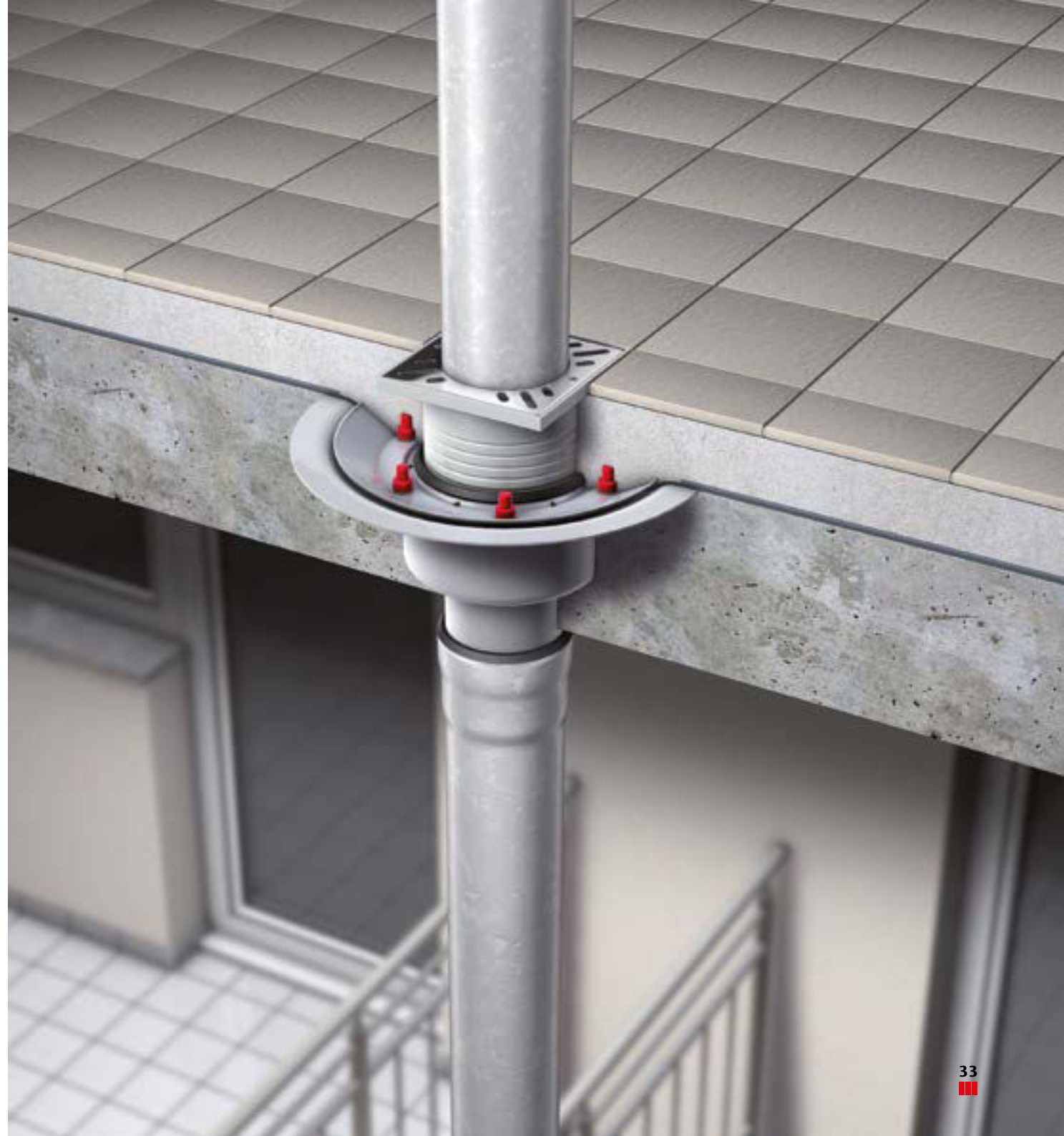





Roof, terraces and façade

ACO Roofbloxx

roof infiltration system

ACO Roofbloxx offers architects, engineers and property owners an environmentally sustainable, efficient and cost-effective method of reducing rainwater runoff that enables water storage and irrigation of blue / green roofs in urban environments. Thanks to its high load-bearing capacity, ACO Roofbloxx makes it possible to construct a drainage roof on many different types of structures, including heat-insulated green roofs, inverted or flat habitable roofs.

ACO Roofbloxx

Product advantages

- The modular structure supports flexibility of design
- Locking of elements in all directions
- Elements stack for ease of shipment and on-site storage
- Shallow rainwater retention
- Capability for passive capillary irrigation
- Suitable for use under both permeable and impermeable surfaces
- High load capacity of over 800 kN / m²
- 100% recyclable
- 90% volume for maximum drainage or water storage

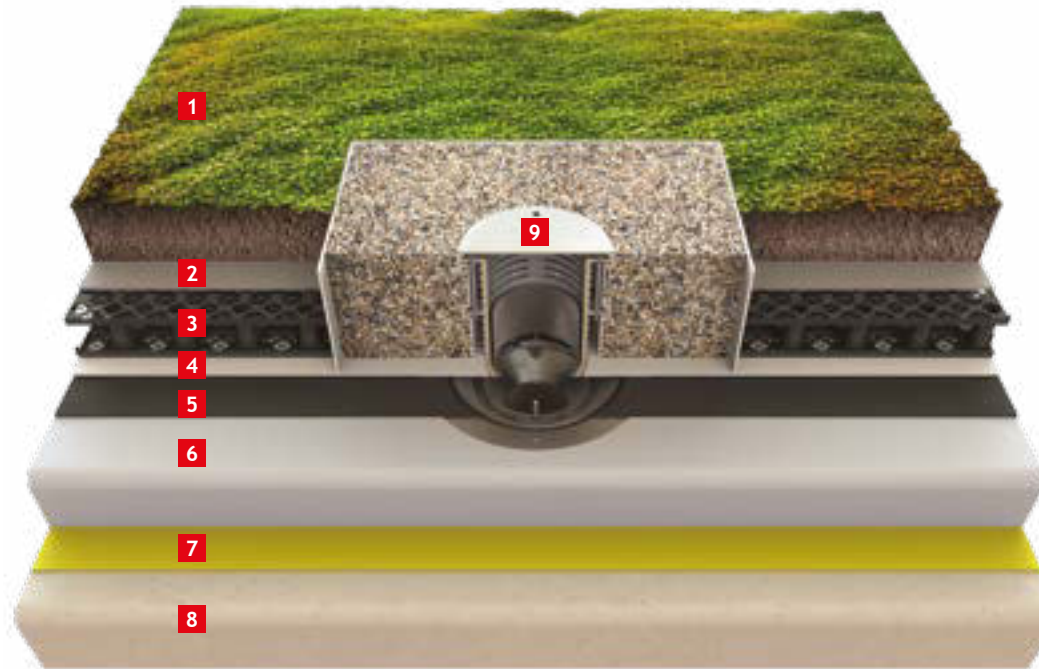

- | | | | |
|---|-----------------------------|---|---------------------------------|
| 1 | Landscaping (200 - 1000 mm) | 6 | Thermal insulation |
| 2 | Geotextile membrane | 7 | Vapor barrier |
| 3 | ACO Roofbloxx (85 - 165 mm) | 8 | Roof slab |
| 4 | Protective membrane | 9 | ACO Blue Roof - flow restrictor |
| 5 | Waterproofing | | |



ACO Roofblox 85



ACO Roofblox 125

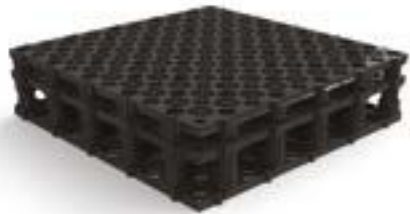

ACO Roofblox 165

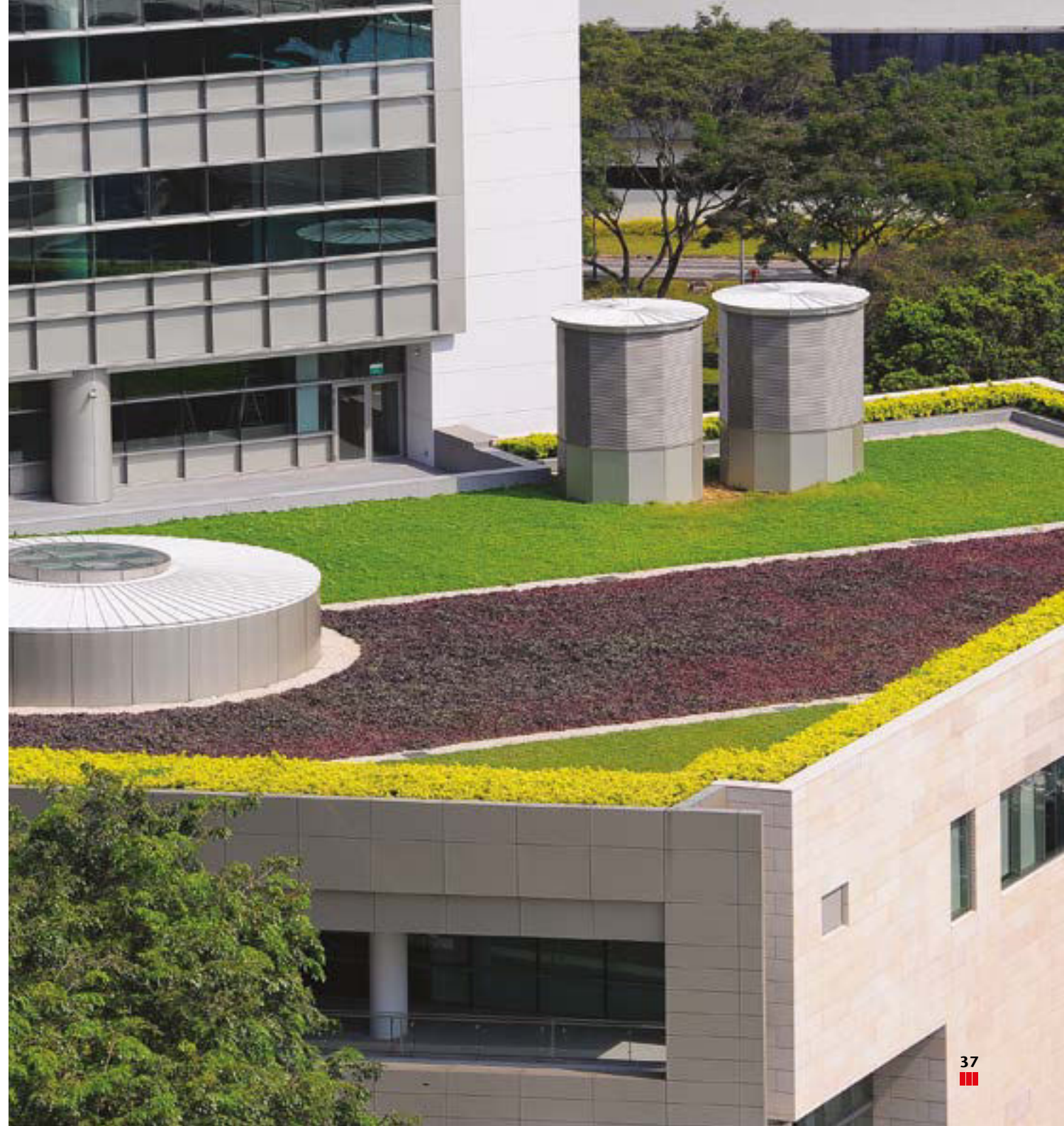

2





Infrastructure

The challenges encountered in the design, construction and maintenance of infrastructure in residential projects include the preservation of a smooth surface, drainage on roads with slight slopes and strategic assessment of flood risk. ACO offers comprehensive solutions to these challenges, ensuring optimal drainage, comfort and safety for foot traffic.

Challenges in the design, construction and maintenance of housing infrastructure

1

Functionality and design

Public residential areas place high demands on both safety and protection during heavy rains and play an important role in overall design and aesthetics consistent with modern standards.



2

Smooth surface and protection against collapse

Road surface damage near drains and covers can put vehicles and passengers at risk.



3

Smart surface water management in the absence of storm sewers

When designing residential complexes with a missing or limited wastewater collection system, the aim is to reduce hydraulic load peak with capabilities for the retention, storage and controlled drainage of surface water.





ACO System solution







Infrastructure

ACO DRAIN® Multiline Seal in

watertight line drainage with gratings

Over the years, ACO has pioneered the setting of standards. Now, once again, the company is offering a sensation in line drainage: a drainage channel with a standard integrated seal, load classes A -E and 1-10 graded slopes. It combines the best of the past 40 years of innovation - watertightness, easy installation and excellent functionality.

The unique combination of the qualities of polymer concrete and an integrated seal create the first fully watertight channel, meeting the requirements of EN 1433. Lots of added value. The new standard of the future: ACO DRAIN® Multiline Seal in.

ACO DRAIN® Multiline Seal In

Product advantages

- Robust channel body made of polymer concrete
- Watertight channel thanks to seal in technology (according to IKT test seal D01059)
- With EPDM seal in the gutter joint as standard
- Easy installation
- Improved self-cleaning thanks to V-cross section and smooth surface
- With Drainlock screwless grate lock

low-profile channel



H - 60, 80, 100 mm
* The right solution for multistory parking garages and areas with limited installation height

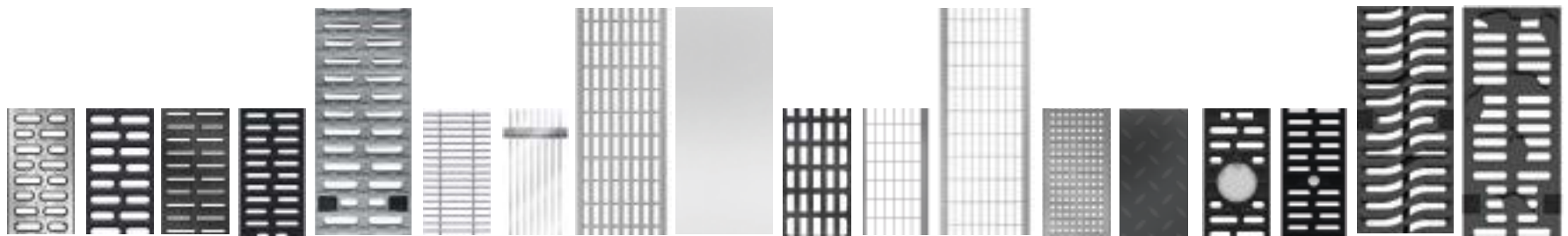
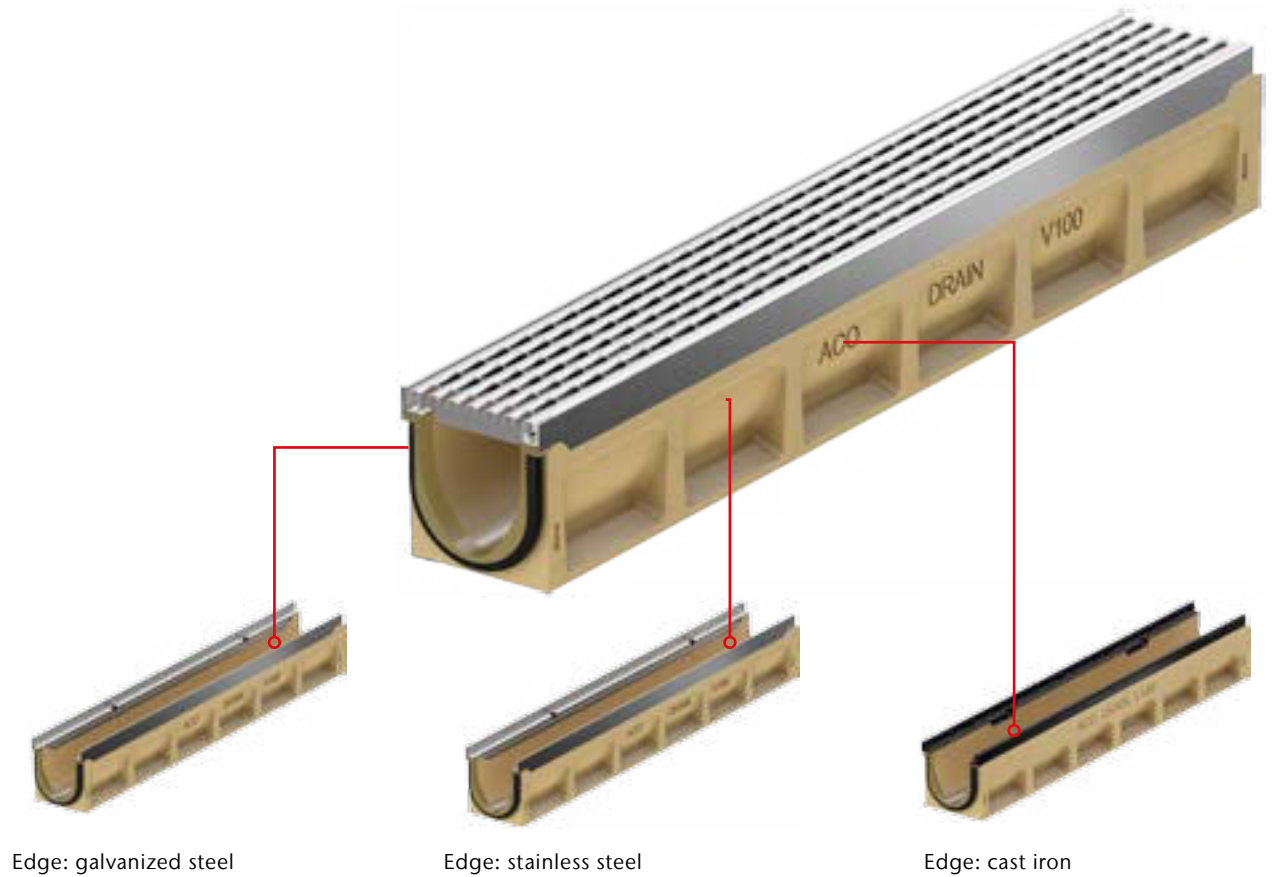



German
Design Award

NOMINEE 2015



reddot design award



ACO Freestyle Gratings

ACO provides architects and designers with hundreds of custom Drainlock design gratings. Four different materials, cast iron, stainless steel, polypropylene and galvanized steel, cover all nominal widths and all load classes of the ACO Drain Multiline and XtraDrain channels. Particular attention is paid to the stainless steel and cast iron variants.

Böblingen
V100



Running Dog
V100/V150/V200



Honey
V150

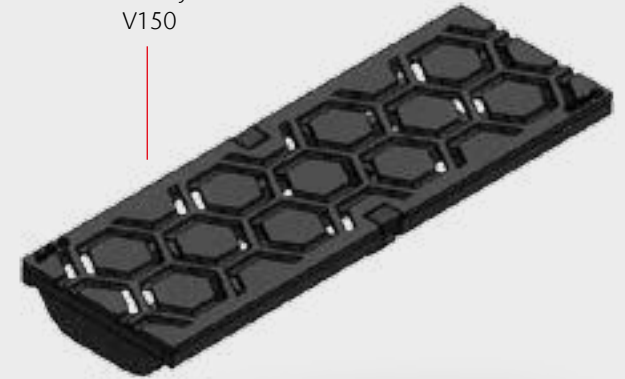

Running Dog
Corner solution

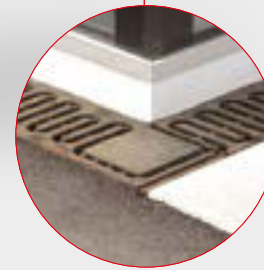

Pearl
V100

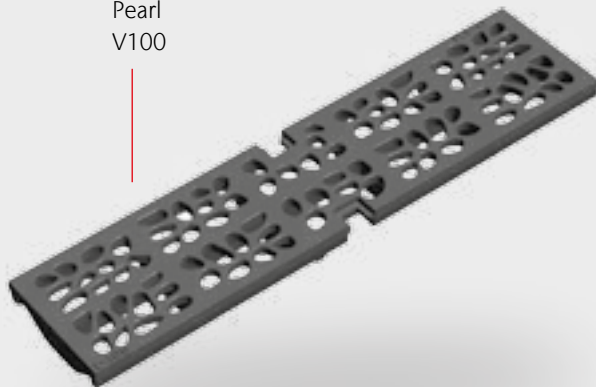

Buffalo
V100



Retro
V150



New models are regularly launched by ACO, gaining prestigious awards for outstanding design and for the attention to details. The ACO Freestyle gratings range made of cast iron allow designers to express their creativity in the grating pattern, actually any theme inspired by the specifics of the project can be reproduced in the casting of the ACO Freestyle grating made of cast iron, ensuring the exclusivity of the design for that project.

Monoblock
V100



Pike
V200

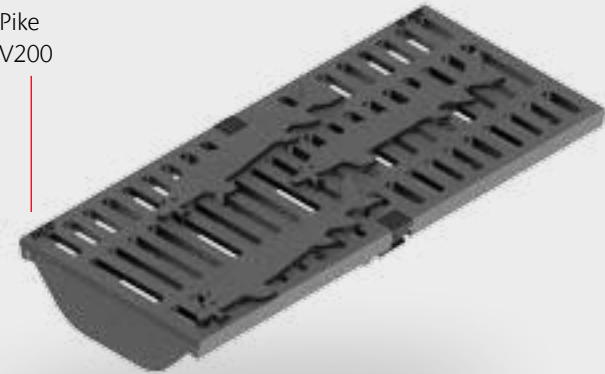

TreeB
V200



DrainBow
V200



TreeA
V200

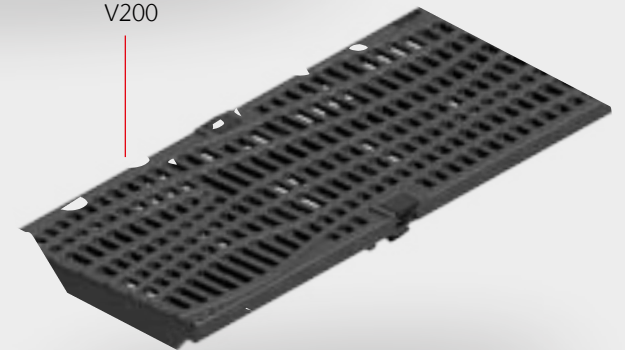

Drops
V300

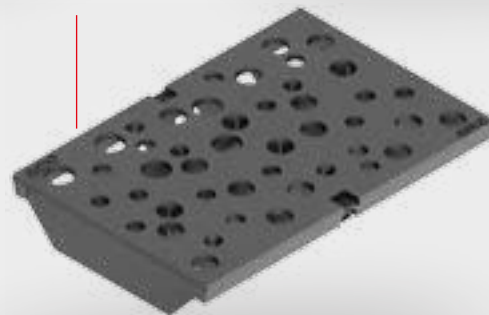

Heide
V300







Infrastructure

ACO KerbDrain

kerbs with integrated drainage

The ACO KerbDrain is a monolithic system that combines a kerb and a drainage channel. The system was developed in response to modern infrastructure requirements for functionality, security and aesthetics.

The ACO KerbDrain supports freedom in the design and layout of roads and parking lots. The system has received the Queen's Award for Innovation in the UK.

ACO KerbDrain

Product advantages

- An elegant solution that combines drain and kerb in a single system
- Possibility of different kerb sizes and profiles
- The ideal solution for level surfaces with longitudinal slopes $\leq 2\%$
- Eliminates the need for point drains and leaves the surface free of gratings
- With no removable parts, a monolithic structure that prevents vandalism

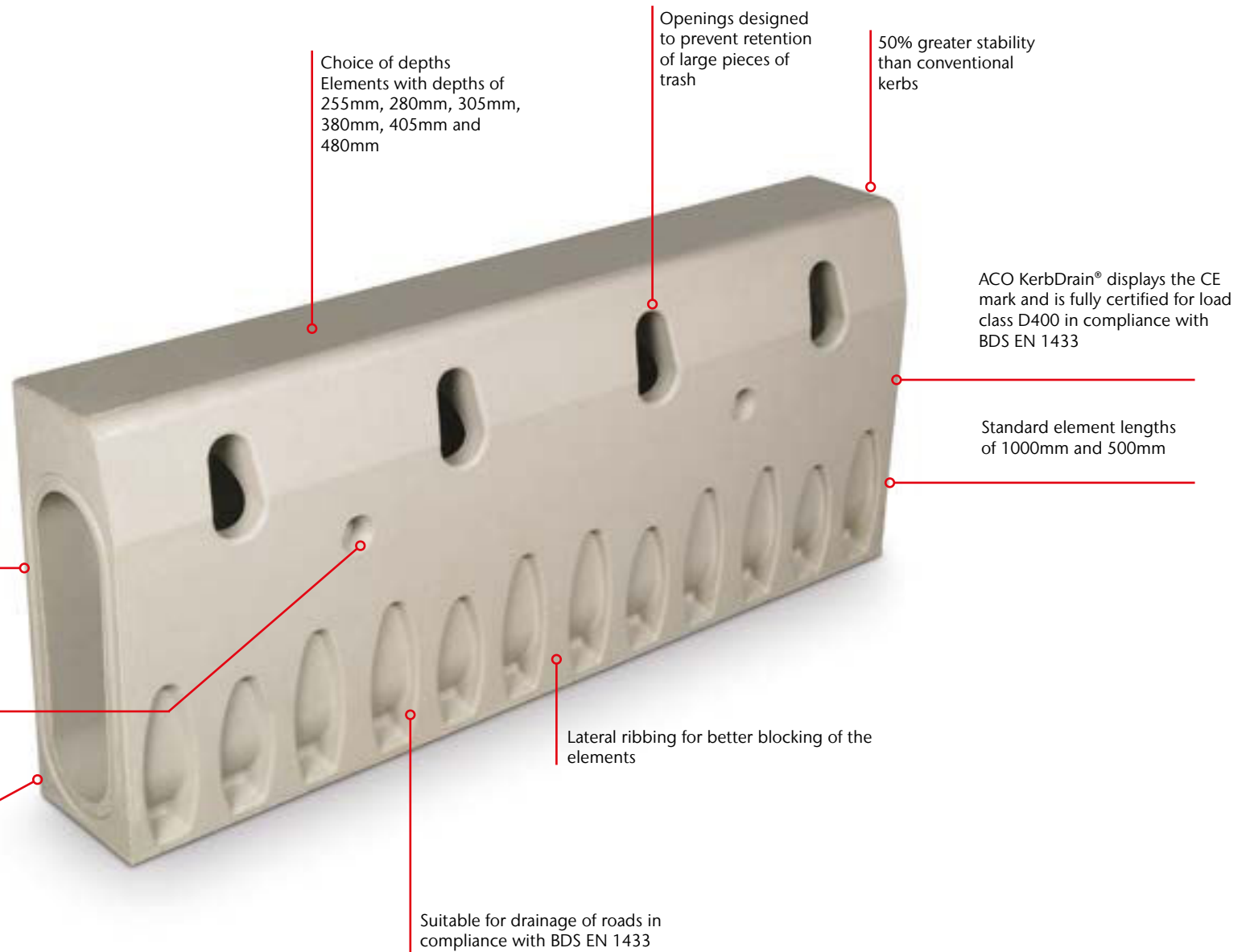



Water collection sump



Inspection element



SP - sloped kerb for longitudinal roads drainage







Infrastructure

ACO Combipoint

street drains with high hydraulic capacity

The ACO Combipoint PP system is the first system that can be rotated, adjusted, telescopically shortened, or installed at an angle while providing a number of advantages in design, installation and operation. ACO Combipoint offers a number of advantages for point drainage. The smart structure distributes the load on the road surface. The grating remains level with the asphalt. The system is designed for a load class to D400, in compliance with EN 124. The product has passed tests for quality, durability and safety and bears a mark per the standard. A hidden bolt lock option is also available.

ACO Combipoint

Product advantages

- Smooth surface - the system distributes the dynamic load
- Total adaptation of the sump body
- Quick and easy installation thanks to its light weight
- Hidden anti-vandalism bolt lock
- Load class D400, in compliance with BDS EN 124: 2003
- Hydraulic capacity of 19.5 L / s



Hidden anti-vandalism bolt lock



Double hinge for opening



Easy opening thanks to the light weight of the grating - 28.5 kg



Bolt-free locking to prevent accidental opening



Minimal risk of clogging thanks to the optimized width of openings



Load distribution system



Bottom with opening



Bottom



Cone



Top piece



Top piece with DN160 outlet







Infrastructure

ACO Multitop Bituplan

self-leveling manhole covers

The innovative ACO Multitop system is designed to meet the modern challenges of road infrastructure. The smart structure of the elements provides for distribution of the dynamic traffic load, which ensures the cover remains at road surface level. The even surface of the installation guarantees safety and comfort without disturbing noises under traffic.

ACO Multitop Bituplan

Product advantages

- A long-lasting and cost-effective solution, 10-year warranty
- Anti-vandalism bolt lock
- Pewepren seals in the frame
- Cover has a non-slip surface
- Able to display an emblem or logo

Load class D400, in compliance with the requirements of BDS EN 124: 2003.



Soundproofing seal made of highly resistant PEWEPREN®



Anti-vandalism bolt lock



Non-slip surface independent of the direction of travel



Element for easy and safe access for inspection

Easy installation thanks to the light weight of the cover and its smart construction.



Ductile iron cover (EN GJS)



Cast iron frame (EN GJL)



Adapter ring



Steel case for installation formwork







Infrastructure ACO

Stormbrixx SD

water storage and infiltration system

The ACO Stormbrixx infiltration system offers an environmentally friendly and efficient solution when there is no sewage system. During infiltration, rainwater is collected in ACO Stormbrixx and then gradually released into the adjacent soil. When environmental protection conditions are not allowing infiltration, ACO Stormbrixx is used as a fully retention tank, with a simple wrapping of geo-membrane to water-proof the system. The adjacent soil must be permeable and there must be no water-retaining layer in the subsoil. No harmful substances may enter the soil or groundwater during infiltration.

ACO Stormbrixx SD

Product advantages

- Structural stability
- Access for inspection up to the full volume of the structure
- Lightweight prefabricated elements for quick and easy installation
- High coefficient of storage
- Sustainable solution for use in parking areas and other areas where water storage or infiltration is required (alternative solution to an evaporation tank)



Main element



Option for installation on 1/2 layer



Top surface cover

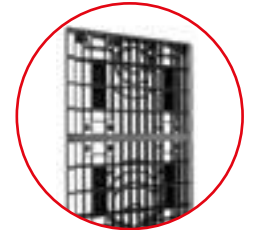

Side element

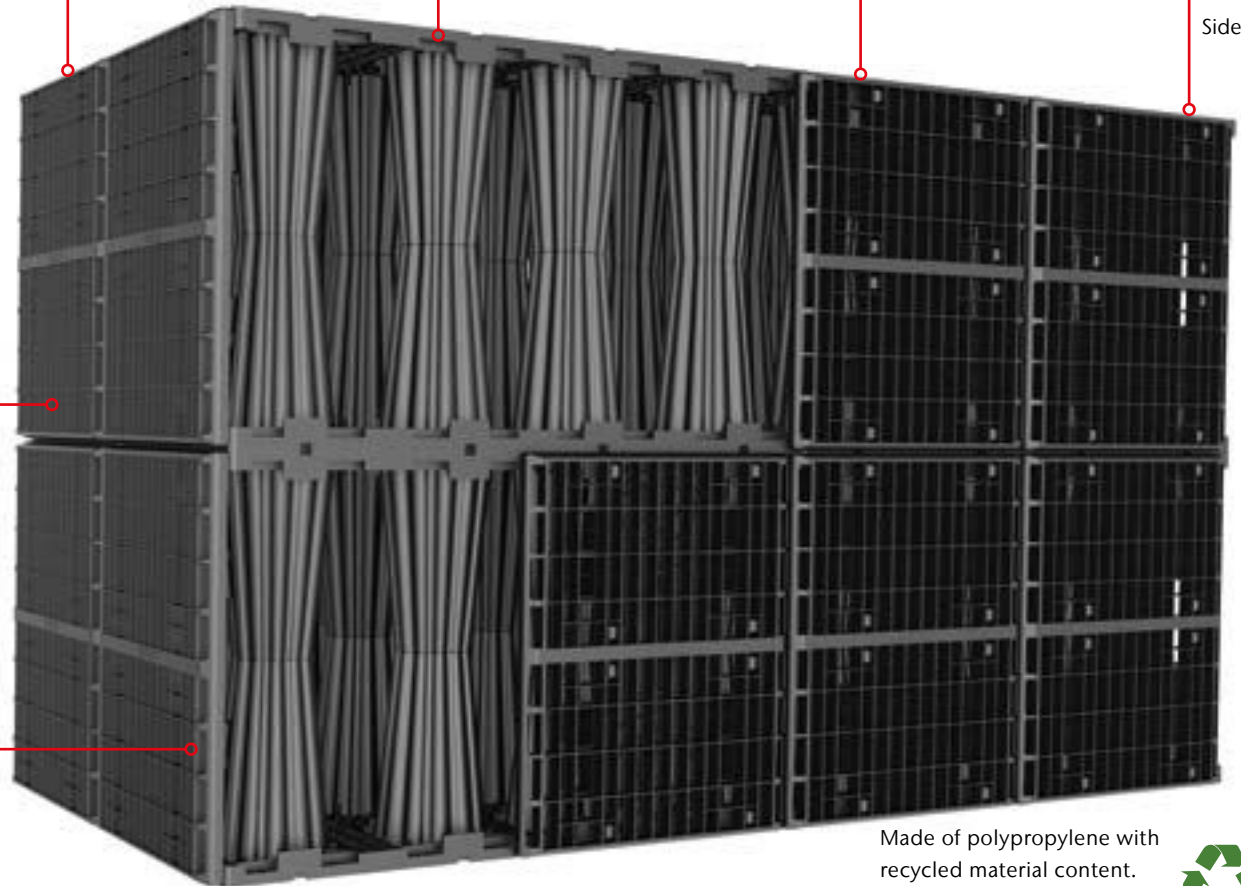

Storage coefficient of 95%. Optimal filling of the system.



Open structure allows free access for video inspection and cleaning

Made of polypropylene with recycled material content.





Visiting cover



Sump top piece



Access plate



Coupling elements for optimal stability of several ACO Stormbrixx SD layers

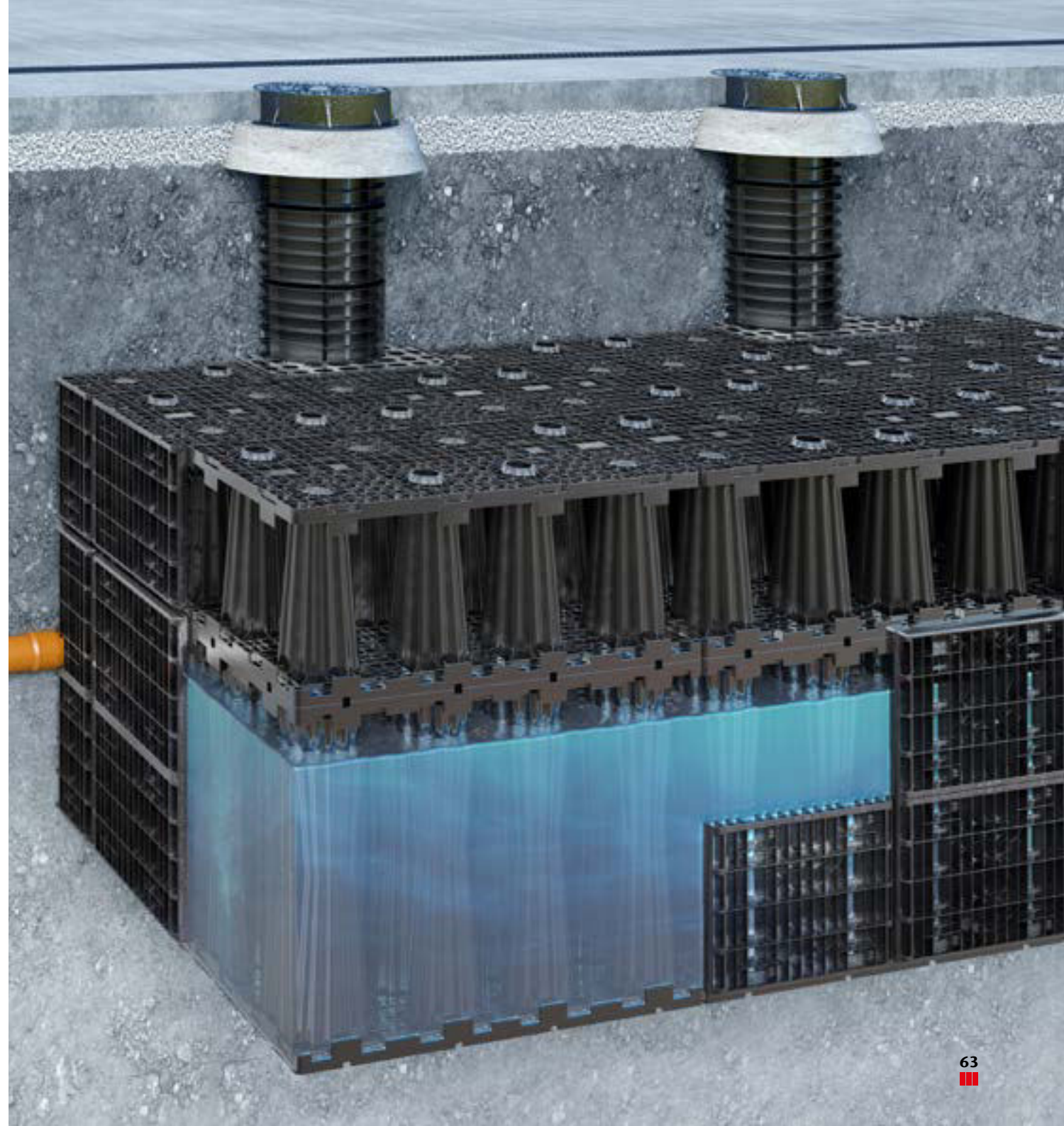

3





Cellar

Modern innovative systems for cellars offer completely new value for spaces below ground level. Fresh air, natural light and protection against flood or moisture provide a variety of opportunities for multiple uses of the spaces beyond storage and building service equipment. With increased extreme weather phenomena, the main priority is flood protection of a structure and the belowground spaces and equipment in them. Providing an effective protection system prevents potential material and financial losses that could affect the overall functioning of a building.

Challenges in the design, construction and maintenance of cellars

1

Watertight installation

Heavy rains have become more frequent and cause significant damage to buildings and infrastructure. Protecting the lower levels of a building from flooding and humidity. The goal is to protect the structure, underground spaces and equipment, and thus the safety and comfort of the occupants.



2

Backflow control

A public sewer can become overloaded during heavy rain, causing cellars to flood. Backflow control ensures that cellars remain dry.

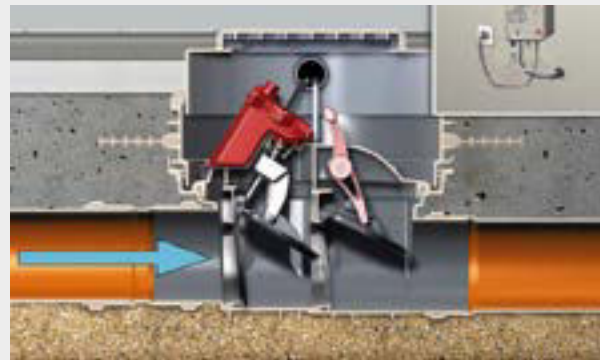

3

Natural lighting

The lack of fresh air or natural light significantly limits the functionality of a building's belowground level. Every square meter is valuable, especially in dense urban areas.



European standards and regulations



The layout and sizing of pumps is done in accordance with **EN 12056-4**, which sets the total head height and total inflow. A pump must be selected for values that reach at least the head height and volume capacity determined at the operating point (taking into account the flow velocity (min. 0.7 m/s, max. 2.3 m/s). The useful volume of a tank (volume between the on and off points) must be greater than the volume of the discharge line (higher than the back pressure to the return elbow) to ensure that the contents of the discharge line are completely replaced during pumping and anaerobic processes cannot develop. When calculating useful volume, the following instructions must be followed: pumps or pump stations

are usually designed for S3 (intermittent operation), i.e., for sufficient pump life (for engine cooling).

ACO System solution







Cellar

ACO Therm Lightshaft system

Courtyard style light shaft

ACO light shafts are a practical and aesthetic solution for ensuring the maximum influx of daylight and fresh air to cellars.

ACO Therm Lightshaft system

Product advantages

- Provide cellars with more light and natural ventilation
- Maximum flexibility and stability
- Easy installation & maintenance
- Smooth white surface for maximum light reflection
- Self-cleaning
- Drainage capability
- Option for thermal protection panel
- Wide selection of gratings and tops

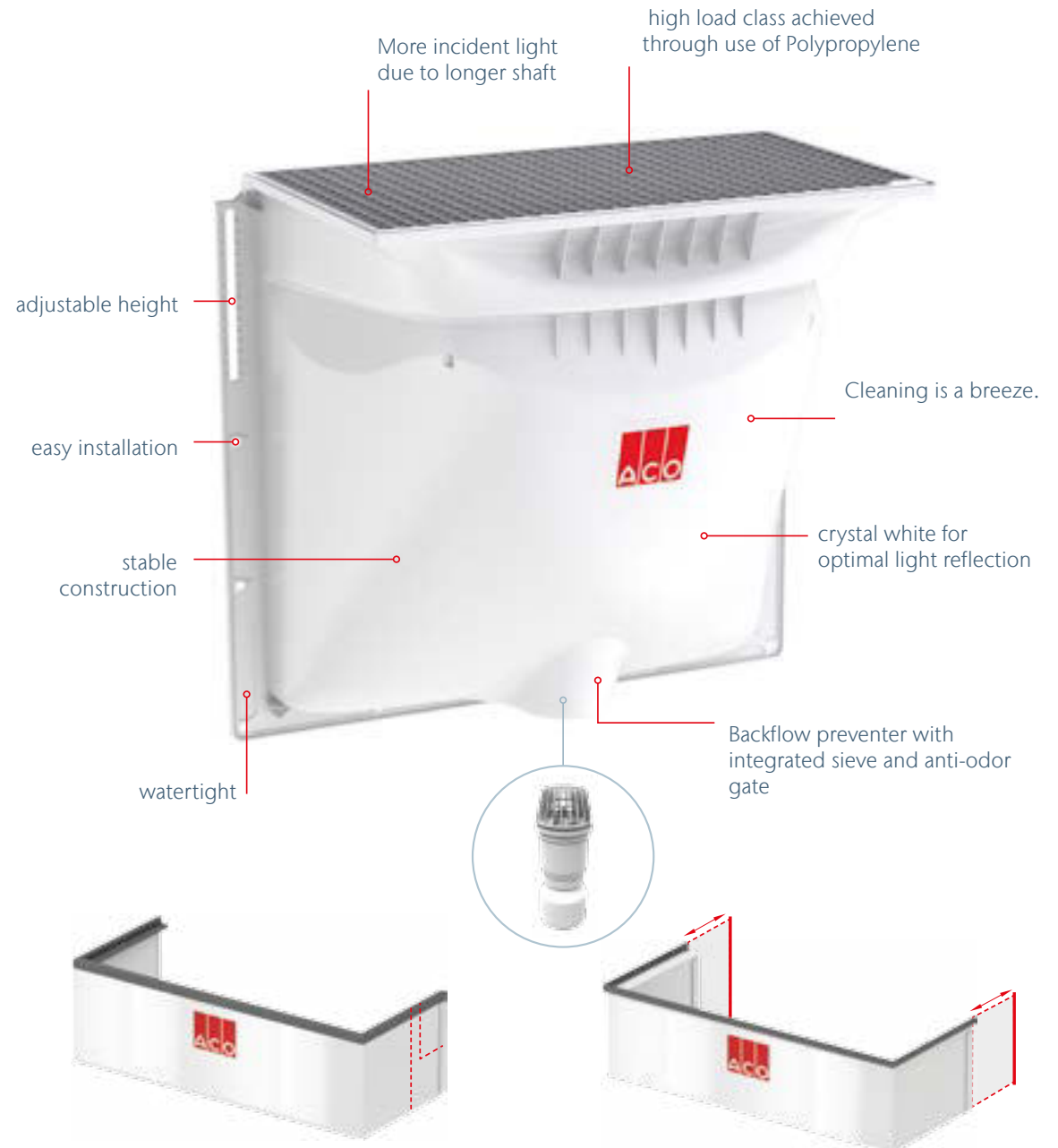

Lengths



400 mm



600 mm

Fixed or height-adjustable tops. Can be cut to meet project requirements.



ACO Therm® Block Standard
thermal insulation panel
Provides thermal insulation,
waterproofing and flood
protection in one system



ACO Therm® Cellular Window

- Triple glazing
- Optimal thermal insulation thanks to a 4-chamber plastic sash and a 5-chamber plastic frame with a profile depth of 82 mm.
- Burglary proof to class RC2







Cellar

ACO ACO Triplex & Quatrix-K

Backflow preventers

Active backflow preventers differ according to the type of wastewater: grey or black. A large number of submersible pumps, pump stations or valves are available for this purpose. Active backflow preventers are used wherever there is no natural slope to the sewer.

ACO Triplex - backflow preventer for grey water

Product advantages

- Made of durable plastic
- Type 2 per EN 13564
- For non-faecal wastewater (grey water) and rainwater collection systems
- With two automatic backflow preventers, one of which serves as a manual emergency valve
- With large opening for cleaning and maintenance

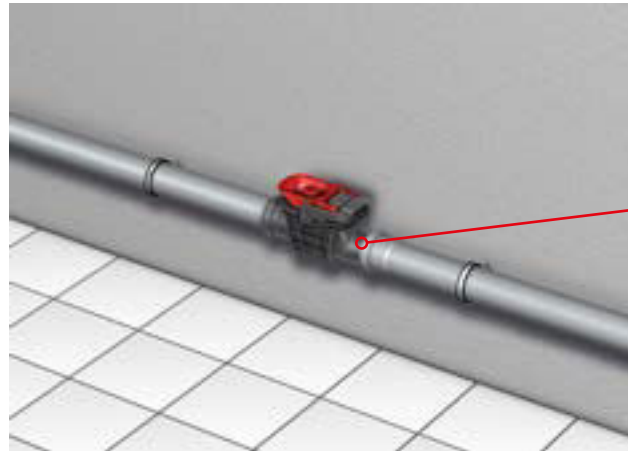

ACO Quatrix K - black water backflow preventer

Product advantages

- For installation in exposed pipes
- Type 3F per EN 13564
- With dual-check backflow preventer
- With automatic seal for operation
- With manual emergency valve
- With opening for large cleaning and maintenance and test pipe
- With IP 54 electrical control unit
- With built-in 4-week self-monitoring
- With visual and acoustic backflow signal

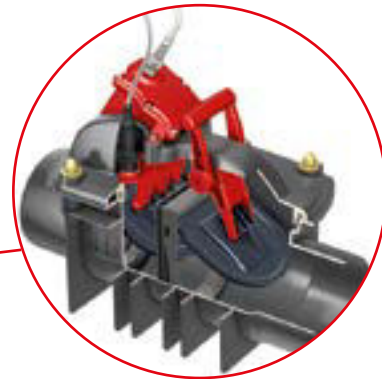

Accessories



Cover with lock

- Suitable for Triplex DN 100
- With emergency unlocking
- Weight: 0.6 kg



Cover without lock

- Suitable for Triplex DN 100
- No emergency unlocking
- Weight: 0.6 kg



Flap

- Suitable for Triplex DN 100
- For additional protection
- Weight: 0.1 kg



Funnel for samples

- ACO backflow preventers
- Weight: 0.1 kg



Tightening screw

- Suitable for Triplex DN 100
- Weight: 0.1 kg



Extension set

- Suitable for Quatrix
- Sensor cable (20 m)
- Motor cable (15 m)



Signalling



Alarm system

- error messages can be transmitted via an alarm system
- Integrated, network-independent alarm
- Indication with siren and LED



Flashing light

- Compatible with dry contact alarm device for fault signal
- 230 V



Siren

- Alarm device for signaling a fault
- Type of protection: IP33, 92 dB(A)





Cellar

ACO MultiMax/MultiStar DDP

Pumps and pump stations

Wastewater is generated in the form of grey water or black water via the building system. Wastewater is fed to the collection tank by means of pumps or pump stations through inlet pipes when the level is below the backflow level. After activation of automatic pumping, the wastewater rises above the backflow level through the discharge pipe. It is then discharged into the public sewer system with a slope and without pressure.

ACO Multi Max F duo - Underground pump station for grey or black water

Product advantages

- For grey or black water
- Made of polyethylene
- Cover load class A15, B125 or D400
- Suitable for single-family homes, residential and office buildings, commercial properties
- Lightweight
- Integrated sludge trap
- Input and output in accordance with BDS EN 877
- Small installation dimensions



ACO Multi Star DDP - Freestanding pump station for grey or black water

Product advantages

- Lightweight
- Several options for inclusion of different levels
- High resistance to chemicals
- High usable volume up to 185 L
- Complete set - ready for operation
- Suitable for use downstream of a grease trap
- Quick installation
- Adapted to the dimensions of door frames: 780 mm



Accessories



Waterproof box

- Dimensions 390 x 1550 x 230 mm (height x width x depth)
- Consisting of: contact: 230 V, 16 A
- CEE contact: 400 V circuit breaker and fuse: 30 mA 30 mA
- On-box heater
- Locking device
- Weight: 16 kg



Flashing light

- Compatible with dry contact alarm device for fault signal
- 230 V



Siren

- Alarm device for signaling a fault
- Type of protection: IP33
- 92 dB(A)



Alarm system

- error messages can be transmitted via an alarm system
- Integrated, network-independent alarm
- Indication with siren and LED



Control unit



Multi Control

- mono and dual versions are available
- Level measurement optional via a 4-20 mA dynamic pressure switch and / or float
- optional: version with Modbus RTU interface
- The standard version of the pressure bell is offered with an analog signal of 4-20 mA or 0-10 V for transmission to a building management system
- multilingual display including offline alarm



4





Underground parking

Parking areas are an integrated part of each residential complex. They are a decisive factor for a building's overall functionality. Whether parking is outdoors and exposed to the elements, located underground or on a slab where construction heights and the presence of other building systems must be taken into account - our wide range of systems and professional services guarantees an optimal solution for parking area drainage.

Challenges in the design, construction and maintenance of underground car parks

1

Effective drainage

Underground parking areas often require drainage solutions with limited installation space and special attention to the areas around access ramps, where slopes and heavy traffic impose special requirements on a drainage system.



2

Design and aesthetics

Modern surface water management solutions are designed to provide additional architectural and aesthetic value to a project with a variety of design options, discreet openings and architectural grating designs.



3

Surface water treatment

Steps to prevent pollution are required at any site, such as car parks, where there is a risk of contaminating surface water with hydrocarbons.





ACO System solution

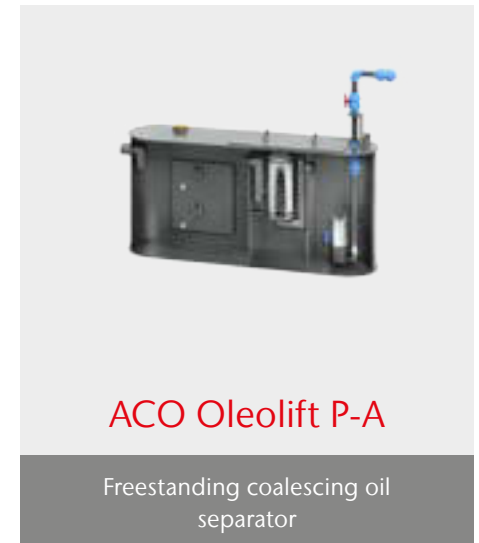
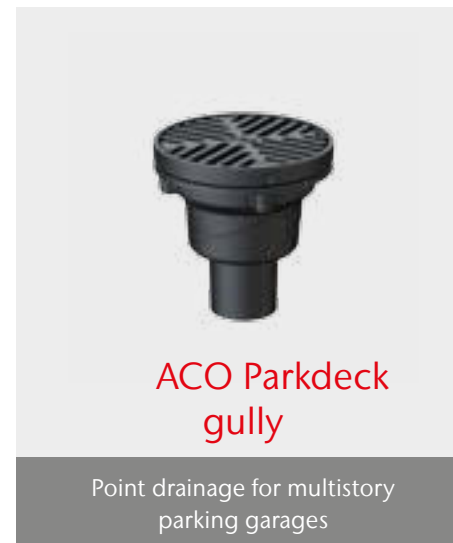
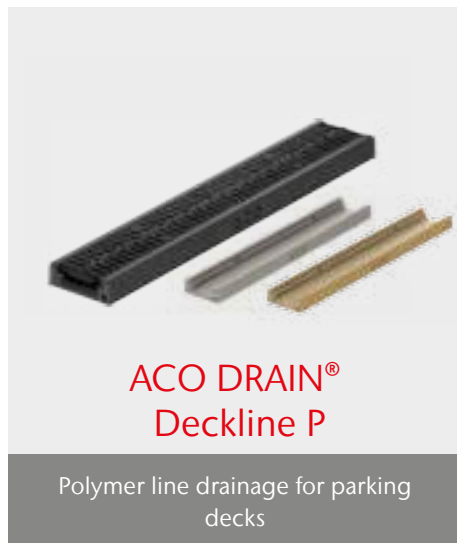





Underground parking

ACO DRAIN® Deckline P

Polymer line drainage for parking decks

Surface water primarily gets into enclosed or multistory parking garages in the form of water dripping or melting from vehicles. This water is contaminated with fuel, oil or road salt and must be completely removed from the drainage system. ACO DRAIN® Deckline drainage channels are 100% impermeable, made entirely of polymer concrete and feature a technically smart design. The low profile of the elements and the minimum construction height make them a preferred solution for installation in floor slabs.

ACO DRAIN® Decline P

Product advantages

- Drainage channels in three colors (nature, grey, anthracite)
- Waterproof polymer concrete
- Quick and easy installation.
- Resistant to light car traffic up to class C250 in compliance with EN 1433
- Recommended solution for asphalt surfaces. Others are also possible
- Nominal widths - 100, 150, 200 mm
- Installation heights - 60, 80, 100 mm

Color selection

Color - nature



Color - anthracite



ACO Drainlock® bolt-free locking
- safe and easy installation and
removal of gratings



Minimum mounting height only
60 mm - suitable for floor tiles

Front and back
faceplates

1 m ACO DRAIN®
Decline P channel

Vertical discharge
channel DN 100

Waterproof stainless steel
flange for attachment to
waterproofing membrane

Choice of gratings

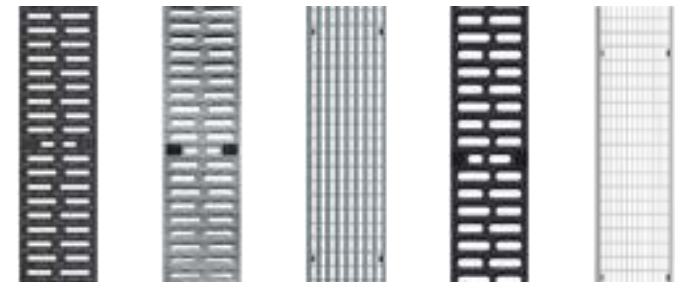

Surfaces



Functional concrete flooring systems support individual technical solutions and attractive colorful design in multistory and underground parking garages.



The road surfaces in garages are traditionally made of asphalt. It is usually very resistant to abrasion, which means that it is much used in heavily trafficked areas such as alleys, exits or ramps.







Underground parking

ACO XtraDrain

Stable MDPE line drainage channels

The ACO XtraDrain system offers a practical solution for drainage of landscaped and traffic areas where a light composite material is employed. Gratings of different materials, designs and load classes offer a wide range of choices to meet the specific requirements of a project. All gratings are equipped with bolt-free ACO Drainlock locking, which facilitates installation and prevents unwanted opening. An additional secret lock is offered for when there are higher requirements for protection against vandalism.

ACO XtraDrain

Product advantages

- Stable MDPE body
- Nominal width 100 mm
- Prefabricated side holes for corner, T-shaped and cross connections
- Lightweight
- Connection profile for quick and easy installation
- Load class to D400 in compliance with EN 1433
- Choice of protective edges made of composite material or galvanized steel



ACO Drainlock® bolt-free locking - safe and easy installation and removal of gratings



Resistance to outdoor conditions (weathering, ultraviolet rays) With no change in mechanical properties.

Dimensions

The ACO XtraDrain channels are 1 m long come in three widths: 100 mm, 150 mm and 200 mm. This gives designers the freedom to choose size and hydraulic capacity by optimizing discharge points and installation costs. The extremely lightweight ACO XtraDrain system is designed for applications up to class D 400 in compliance with EN 1433. The main advantages of the system are the possibilities for configuration during design and the incomparable ease of operation. Technical details such as the proven V-section and the hexagonal structure of the channel meet all requirements for a modern drainage channel.

Low profile channel X 100



Channel X 100



Channel X 150



Channel X 200

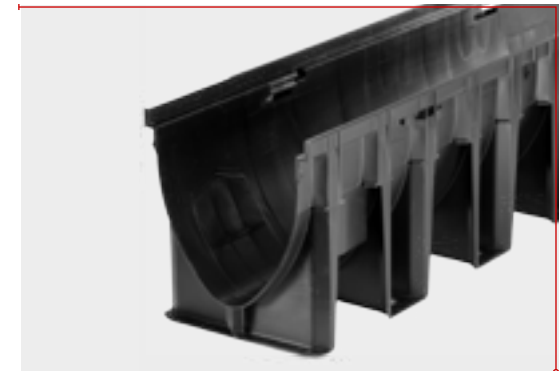

Accessories



Combination endcap for front and back of a channel

- Heights 150, 210, 265 mm
- Weights: 0.1 kg



Endcap for horizontal discharge

- Heights 150, 210, 265 mm
- DN 110, 160, 200
- Weights: 0.2 kg



Vertical discharge adapter

- Heights 150, 210, 265 mm
- DN 110, 160, 200
- Weights: 0.1 - 0.3 kg



Water trap with rubber seal

- DN 110, 160, 200
- Weight: 1.2 kg



Inspection shaft with adapter

- Height 512 mm
- DN 110, 160, 200
- Weights: 2 - 4.9 kg







Underground parking

ACO Parkdeck gully

Point drainage for parking lots

ACO gullies offer a solution for all load classes. The trend towards larger and heavier vehicles poses new challenges for drainage components. Cast iron has exceptional compressive strength and can easily withstand extreme loads.

ACO Parkdeck gully

Product advantages

- Durable cast iron body, construction class A1 - non-flammable
- High corrosion resistance for long service life
- Load class: M125
- Compact shape, bare diameter only 160mm
- Secure fire protection class R30 - R120
- Optional flange for attachment to all types of flooring



Resistance to outdoor conditions
(weathering, ultraviolet rays)
With no change in mechanical
properties.

Round shape DN 70



Square shape DN 70



Round shape DN 100



Square shape DN 100



Smart height adjustment

Compensation and height adjustment is especially important for accommodating different surfaces. The ACO Parkdeck gully adapts smartly to any surface height. With a convenient rotating mechanism, the frame can be adjusted to the desired height in 5 mm steps. Two adjustment rings offer an additional solution for heights over 20 mm.



Accessories



Heating element

- Network Connection: 220-240V AC
- Protection: IP 67
- Height: 95 mm
- Weight: 0.3 kg



Element for fire protection

- Appropriate for DN 70, DN 100
- Weight: 0.5 kg



Adapter ring

- Adjustable height 25-40 mm
- Load class M125
- Weights: 1.3kg



Adapter ring

- Adjustable height 45-60 mm
- Load class M125
- Weights: 1.9kg



Silt basket

- Material - stainless steel







Underground parking

ACO Oleolift P-A

Freestanding coalescing separator for petroleum products

Oleolift P-A freestanding coalescing separators are designed to remove petroleum substances (mineral oils, petrol, light metals) contained in rainwater and manufacturing process wastewater. The built-in settling tank additionally removes suspended solids. Thanks to a system of pumps and accessories, the separator can be installed in places below the public sewer gravity discharge point.

ACO Oleolift P-A

Product advantages

- Freestanding coalescing separator for oil products, with built-in settling tank and dual pump
- Separator with plastic floating switch, for light liquids with a density up to 0.90 g / cm³
- High material stability
- Easy installation thanks to light weight
- High operational reliability and long life
- Structural stability guaranteed for 50 years
- All nominal sizes are tested by an independent testing institute (LGA) - test report

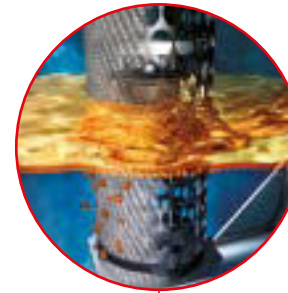

Coalescing filter
Easy to clean - durable wire mesh material



Choice of cover



Option 1
Basic plastic cover with handle



Option 2
Durable plastic cover with handle, seal and metal clamping ring



Dual pump
high operational reliability, equipped with control panel



ACO Multicontrol Duo
control panel for dual pump

Accessories



Monitoring device and alarm - Securati idOil 20

- allows combined or separate monitoring of the level of oil, sludge and liquids over an electrical connection
- 230 V/50 - 60 Hz
- IP 67
- Cable 5 m



Sampling device

- Consisting of a hand pump, suction connection, connecting hose and bolt connection
- Weight: 3 kg



Drainage set to suction pipe DN65

- Consisting of PE-pipe, Storz-B connector, clamping elements and bolts



Valve



Inspection port







Underground parking ACO Oleopator G

Compact coalescing separator for petroleum products for underground installation

All ACO separators for oil products comply with EN 858:2003. They are hydraulically tested and certified by an independent laboratory.

ACO Coalisator P

Product advantages

- Vertical tank made of glass reinforced plastic - no heavy machinery required, resistant material
- Nominal sizes from 3 up to 50 l/s
- Includes coalescence filter
- Coalescence insert and float can be removed for cleaning without having to empty the separator
- Complies with standards EN 858-1
- Inner parts made of PE-HD
- Easy accessibility guaranteed for maintenance, cleaning and disposal thanks to removable cage component

Additional Elements



Top sections
with cover, load class
A 15 -D400

Top section with cover,
optionally, can be equipped
with concrete plate

Cast iron cover,
load class D400

Inlet

Outlet

Coalescing filter
Easy to clean - durable wire
mesh material

Accessories



Alarm device

- Monitoring device, 2x cable connections, oil level sensor, overflow sensor
- Weight: 3 kg



Control unit GA1

- Alarm device for indicating when it's time to empty the oil separator and thus prevents harmful grease emission to the sewer system
- Made of polycarbonate



5





Bathroom

The ACO ShowerDrain product line offers elegantly designed bathroom drainage solutions. The line meets the requirements of designers and architects for homogeneity and the absence of thresholds and barriers on the floor surface. ACO ShowerDrain design solutions combine the look of a classic bathroom with that of a modern and luxurious spa. The pursuit of high quality is not limited to the design, the materials and the finished line - safe operation and easy installation are also a high priority.

Challenges in the design, construction and maintenance of bathrooms and spas

1

Barrier-free movement

The idea of a flat floor surface and a spacious room requires optimisation of materials, transitions between them and removal of any visual barriers. This trend is particularly prevalent in residential buildings, where freedom of movement and access for people with disabilities, adults and children should be facilitated as much as possible.



2

Quality

The high quality of bathroom materials is essential both for durability and for creating harmony between different surfaces, as well as for ensuring safety and easy maintenance. Special attention is paid to reliable joints between elements on the surface to achieve a completely waterproof coating, protect the structure and prevent health risks.



3

Support

Easy and efficient maintenance is vital, both for the comfort of guests and for hotel operating costs. This is especially important in bathrooms and sanitary facilities. Rounded corners and flat surfaces offer harmonious design and easy cleaning. Surfaces must also stand up to cleaning with detergents.



European standards and regulations



Bathroom drainage systems are certified according to **EN 1253**, which determines the minimum runoff coefficient for drainage of buildings. The drainage flow rate for the nominal diameter of a DN 50 outlet pipe is 0.8 L/s. This value is achieved in tests with a 20 mm water column above the grating. With point drainage, four slopes to the floor trap can produce this water column. When installing shower channels, it is rare in practice to reach a 20 mm water column due to simple slopes (single or double) of the floor structure. Therefore, the flow rate is calculated in tests with a maximum water column of 5 mm. The flow rate is taken as

the value without a water column when the drain is located at a shower's perimeter and when there is no glass partition. When the shower channel is installed next to a wall, a short water column is possible, depending on shower dimensions. For example, if a shower area is one meter deep and has a slope of 2° to a shower channel installed next to the wall, that means a 5-mm water column is formed 25 cm from the wall.

ACO System solution

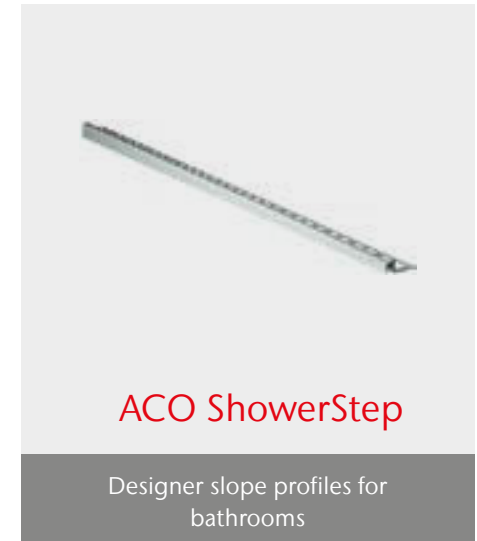
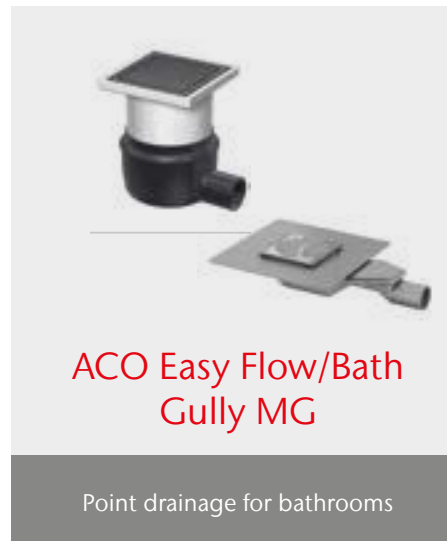
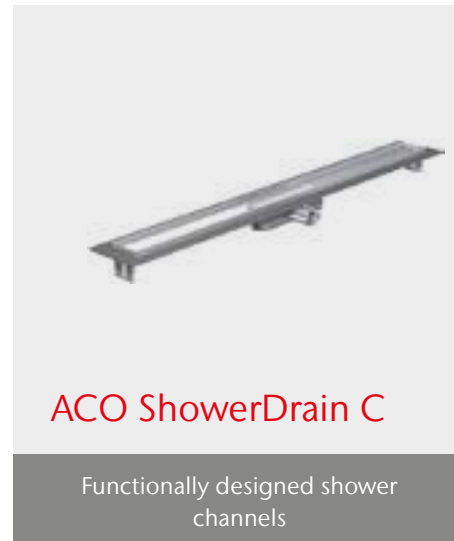





Bath and spa area

ACO ShowerDain E+

Shower channels of high-quality electropolished stainless steel

The ACO ShowerDrain E+ shower channel series provides effective drainage of the bathroom and supports freedom of design and flooring choices of different thicknesses. The factory-installed waterproofing flange provides even better adhesion to oily waterproofing and guarantees the watertightness of the entire shower area. The shower channels of the ACO ShowerDrain E + series are available with horizontal or vertical drainage when a hanging sewer line is used. Whether you opt for a version with horizontal flanges or a vertical flange for wall mounting - the choice is entirely yours.

The ACO ShowerDrain E + series is fully tested and certified according to EN 1253.

ACO ShowerDrain E+

Product advantages

- Shower channels of high-quality electropolished stainless steel
- Factory installed geotextile flange for attachment to oily waterproofing
- Two-level drainage by means of seepage openings
- Wide range of designer gratings
- Versions with horizontal and vertical drainage
- Easy height adjustment
- Supporting lugs for easier installation



reddot design award



ShowerDrain E + with vertical flange



ShowerDrain E + with horizontal flange



Your individual inscription or design

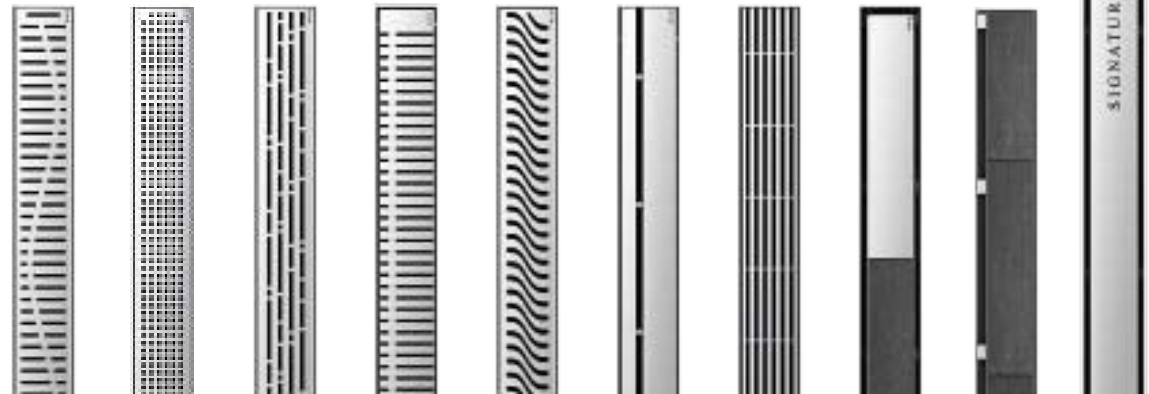

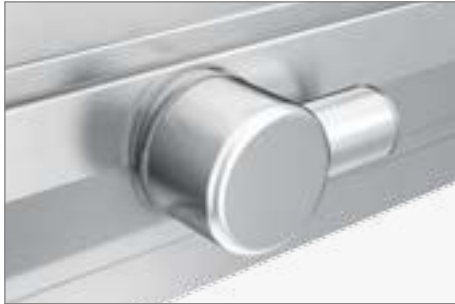

Factory installed trap - 100% watertight

The ACO ShowerDrain E + comes fully assembled. Therefore, no additional assembly is required. The stainless steel trap is guaranteed to be tightly welded to the channel body at the factory.



Electropolished stainless steel

The built-in tile frame facilitates installation and ensures level placement. The rounded shapes ensure both harmonious design and easy cleaning.

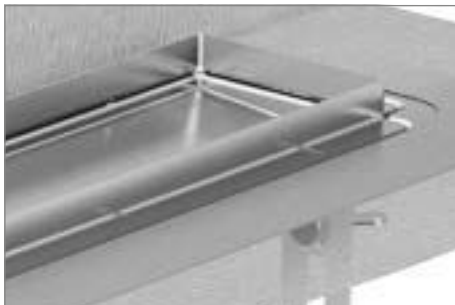

Factory installed waterproof flange

Thanks to the elastic material, a high level of security is guaranteed when closing gaps between shower channel and screed.







Bath and spa area

ACO ShowerDain S+

Easy installation and assembly. Easy cleaning service. Functional design

Innovative design with advanced technology: The new ACO ShowerDrain S+ shower channel combines aesthetics and excellent functionality.

The elegant profile of the shower channel, made of electropolished stainless steel, fits all common tile formats and is an excellent solution for shower drainage with several additional advantages.

ACO ShowerDrain S+

Product advantages

- Designer bathroom drain of electropolished stainless steel
- Set containing shower channel and water trap for installation in a pipeline
- Drainage outlet suitable for all pipe systems with couplings
- Excellent hydraulic capacity up to 0.6 L / s
- Two-piece water trap, removable
- Elegant stainless steel gratings



reddot design award

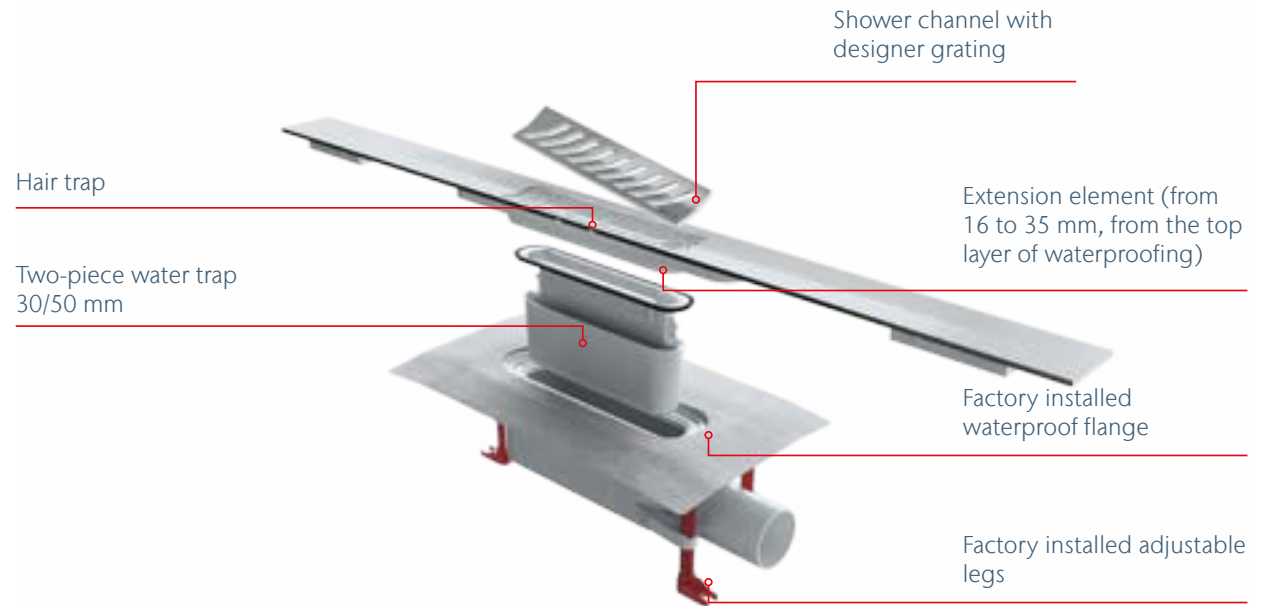

Functional design

The profile can be shortened on site and allows maximum adaptation and precise connection to the profile for changing the slope.



Stripes grating



Plate grating



Fast and easy to install

Height adjustment by means of mounting screws, which can be shortened if necessary, without the need for additional tools.



Functional design

The elegant contour of the stainless steel shower channel makes an impression with its clean design. Its built-in slope permits optimal drainage and easy maintenance.



Easy cleaning.

Thanks to the Tip & Flip function, the grating can be removed easily and without tools, simply by pressing lightly on the corner. The hair and water traps can also be easily removed for cleaning.







Bath and spa area

ACO ShowerDain C

A functional solution

ACO offers the ACO ShowerDrain C shower channel for large projects. This standardized product is a functional and economical solution for investment projects. There are three designer stainless steel gratings to choose from - Square, Wave and Slot, as well as a Tile option - for embedding flooring material in the grating. You can choose the version with horizontal flanges or the one with a vertical flange on the longitudinal side suitable for wall mounting.

ACO ShowerDrain C

Product advantages

- Designer drainage for a stainless steel bath
- Choice of grating design
- Excellent hydraulic capacity up to 0.6 L / s
- Choice of standard sizes and flanges for attachment to waterproofing
- Suitable for all flooring heights
- Material: Stainless steel 304
- Load class: K3
- Channel internal width 64 mm
- Hydraulic capacity
 - 0.5 L / s (without water column)
 - 0.9 L / s (with 20 mm water column, according to EN 1253-1)

ShowerDrain C with vertical flange



ShowerDrain C with horizontal flange



ShowerDrain C without flange



ShowerDrain C, vertical discharge

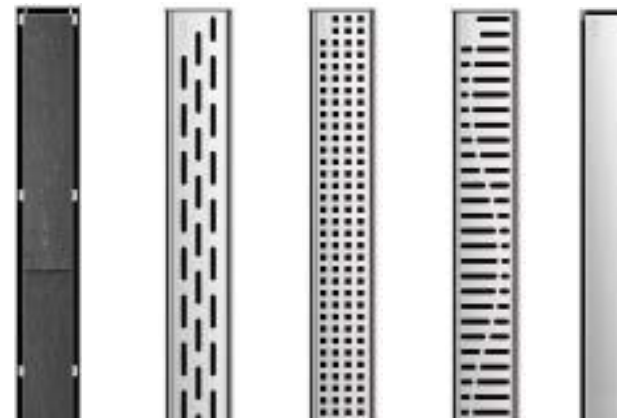

New



ACO ShowerDrain C Black



Factory installed trap

Thanks to its new drainage body and more compact form, the ShowerDrain C achieves an excellent hydraulic capacity of up to 0.9 L/s despite its low installation height.

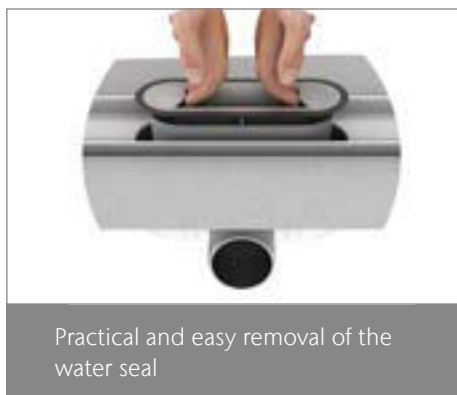

Practical and easy removal of the water seal

With the help of two additional grips, the water seal can be easily removed. There is also unobstructed access to the interior of the shower channel, which can be easily cleaned.



Free access for pipe inspection

Once removed, the water seal can be disassembled into two separate parts for cleaning. The special design of the drain body provides free inspection access to the pipe and prevents water retention.







Bath and spa area

ACO ShowerDain Flex

Custom length shower channels

ACO FlexDrain is a reliable and flexible solution for public showers in swimming pools and spa areas. The channels can be ordered in lengths to meet specific requirements. The internal longitudinal slope of the bodies ensures efficient drainage. Stainless steel gratings in various designs offer aesthetic design, safety and easy cleaning.

ACO ShowerDrain Flex

Product advantages

- Shower channels with a single element up to 3 m long.
- Individual connecting elements without visible breaks
- Made of stainless steel class 1.4404 (AISI 316) or 1.4301 (AISI 304).
- Visible width 90 mm
- Horizontal flanges for attachment to oily waterproofing
- Vertical flange option for wall mounting
- Built-in internal slope of the channel
- Possibilities for individual solutions (angular, T-shaped connections, etc.)



Choice of gratings

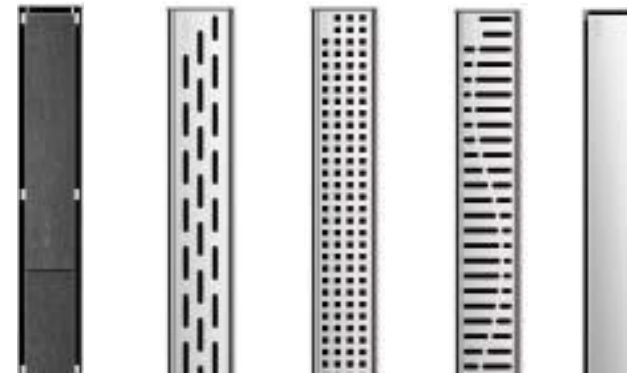



Smooth surface for self-cleaning

The high-quality stainless steel shower channels are easy to maintain and resistant to detergents.



Factory installed trap - 100% watertight

The stainless steel traps are welded tightly to the channel body at the factory, ensuring optimal drainage and watertightness.



Installation aids for leveling

Maximum adaptation and precise connection to a profile for changing the slope, thanks to the factory-installed installation aids for leveling.







Bath and spa area

ACO Slot 8

stainless steel slot drain

Discreet and unobtrusive, the ACO Slot 8 drainage system offers a new approach to draining terraces, indoor and outdoor pools, and wellness and sanitary areas. The narrow slot eliminates the need for a grating and forms a clean, continuous line on the surface. The system is made of stainless steel with an integrated slope in the channel body, allowing for faster drainage without retention on the channel bottom and providing greater self-cleaning performance. The inspection element allows easy access and maintenance.

ACO Slot 8

Product advantages

- Drainage system with low construction height
- Suited for use around swimming pools when the areas subject to cleaning and the water return zones must be kept separate
- Made of high-quality stainless steel
- Modular system manufactured to individual size
- Segments up to 3 m long and flanges for optimal connections
- Suitable for pedestrian traffic, the width of the slot is safe for barefoot traffic

Channel with or without built-in slope



Channel with vertical drainage



Detail of attachment to waterproofing and horizontal drain

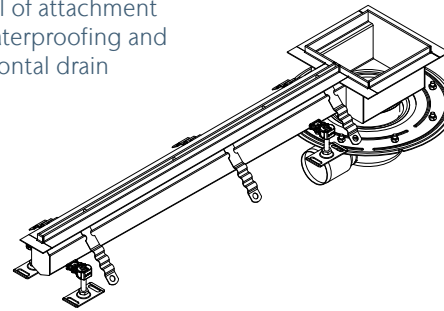

Detail with inspection cover DN50 / DN75

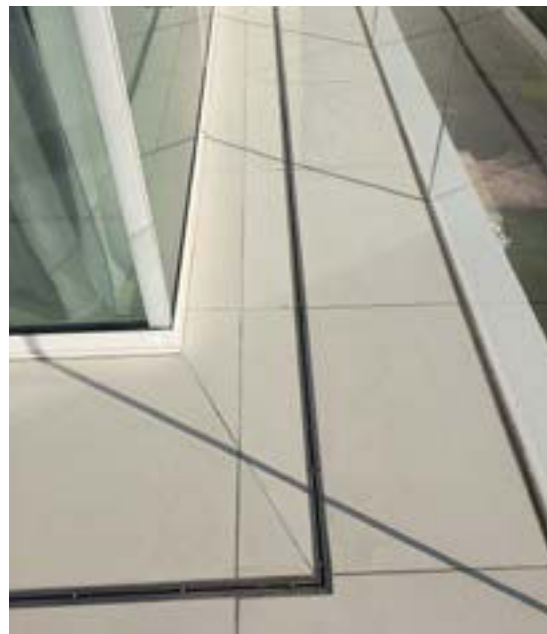
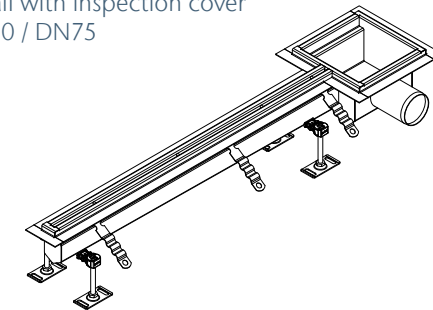

ACO Slot 8/14

- Slot width 8 mm
- Overall inlet width 14 mm
- Made of stainless steel AISI 304 or AISI 316 L
- Channel bottom has a built-in slope to the outlet from 60 to 120 mm
- Extended edge option for waterproofing
- Installation anchors for securing in concrete and leveling

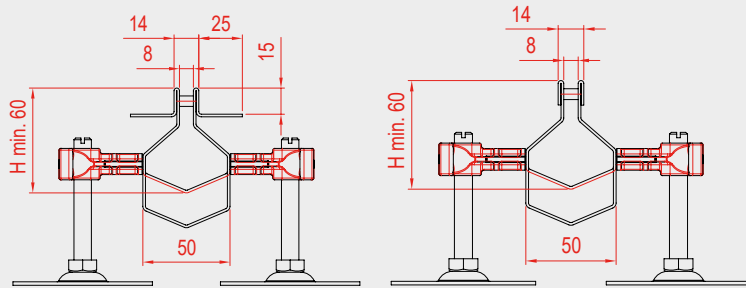

ACO Slot 8/38

- Slot width 8 mm
- Total inlet width 38 mm
- Made of stainless steel AISI 304 or AISI 316 L
- Channel bottom has a built-in slope to the outlet from 60 to 120 mm
- Extended edge option for waterproofing
- Installation anchors for securing in concrete and leveling

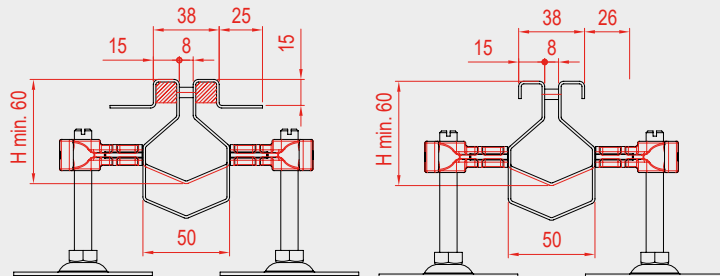





Bath and spa area

ACO Easy Flow

Designer point traps

The ACO Easy Flow bathroom drain is used where efficiency and aesthetics must be in sync. The convenient modular system allows the floor traps to be combined with different types of round or square gratings depending on individual requirements - optional, with or without flanges for waterproofing. Depending on drain size, the point drainage has a hydraulic capacity of up to 2.0 L / s. Optimal room drainage is guaranteed.

ACO Easy Flow

Product advantages

- Meets the requirements of EN 1253-1
- Solutions for different tile thicknesses and flooring structure heights
- Optimal access to the pipe system after removal of the water seal
- Replaceable fire protection set AbZ: Z-19.17-2159
- Material: Plastic
- ABS upgrade
- PP trap
- Drain outlet: Suitable for all types of pipe systems

The ACO Easy flow features a top for embedding of flooring



Installation heights



DN 50



DN 70



DN 50



DN 100



DN 50



DN 70 – DN 100

Choice of gratings



Wave



Quadrato



Forest



Hawaii



Mix



ACO Bath Gully MG

Product advantages

- Meets the requirements of EN 1253-1
- Minimum installation height
- Flange for attachment to waterproofing
- Optimal access for cleaning
- Complete system







Bath and spa area

ACO ShowerStep

Designer slope profiles for bathrooms

The ACO ShowerStep gap wedge is designed for installation when a shower has different slopes. This bathroom is floored completely with tiles, laid flat without a slope, while the tiles in the shower area are sloped 1.5-2% in one direction to the shower channel. The slope in the shower area creates a difference in the heights of the two parts that increases toward the shower channel.

ACO ShowerStep

Product advantages

- Three heights (10, 12.5 and 15 mm) for different flooring thicknesses
- Two standard lengths
- Pre-prepared slope
- Easy installation
- Material: Stainless steel 304
- Upper surface: 12 mm, for installation with or without a glass partition
- Ready for installation
- Length: 990 and 1490 mm; can be shortened during installation
- Versions: options for installing on left side or right side

Polished / Electropolished



Black

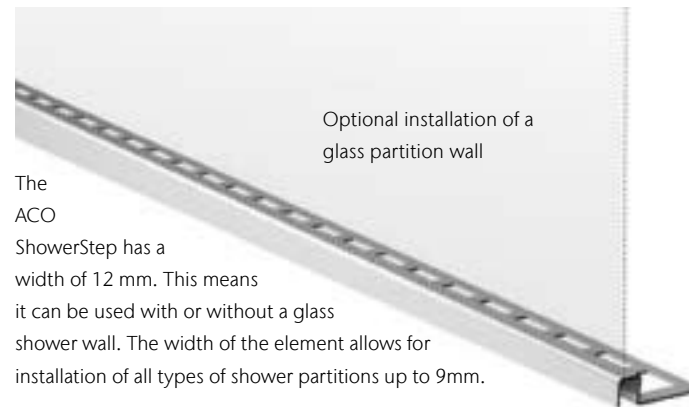
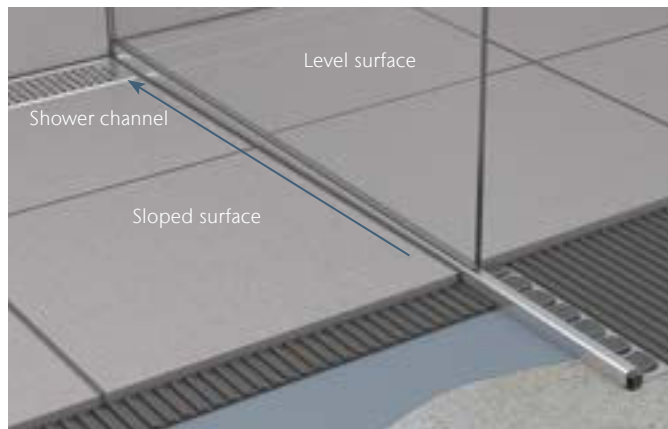

ACO ShowerStep - design transition
for a slope

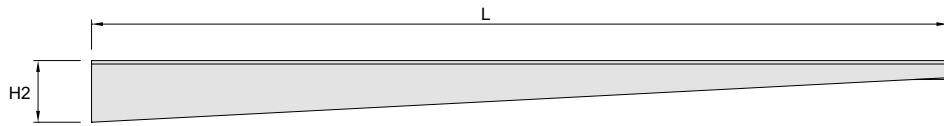
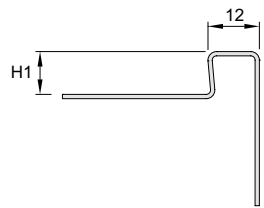

6





Open areas

The design of landscaping and pedestrian areas is an integral part of modern architecture and is especially important for the aesthetic appearance and comfort of residents. As the intersection of architecture and nature - landscape architecture responds to the challenges of simultaneously ensuring sustainable protection of the environment and protection and design of surfaces, while also providing comfort and safety.

Challenges in the design, construction and maintenance of outdoor areas

1

Waterproof surfaces

The expansion of communities and the construction of paved areas mean less and less natural infiltration of water. This requires greater investment in sewage systems to absorb the increased surface flow.



2

Functional requirements

Contemporary landscape architecture is a balance between creative and construction challenges. On one hand, it is important that an area is comfortable and safe for pedestrians or potential car traffic. On the other, the plants in an area must have a suitable living environment and protection from damage.



3

Aesthetics

Green areas are a vital part for a habitable environment. Integrating them into any project is important to making people feel comfortable. Modern landscape systems protect the natural environment and, at the same time, are integral to a project's design, in keeping with the architectural surfaces.



European standards and regulations



ACO System solution

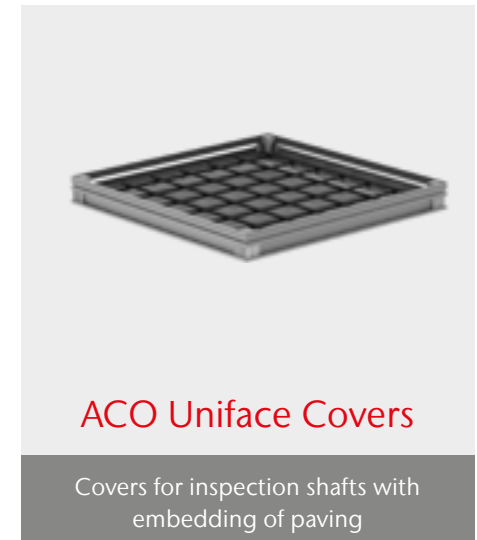
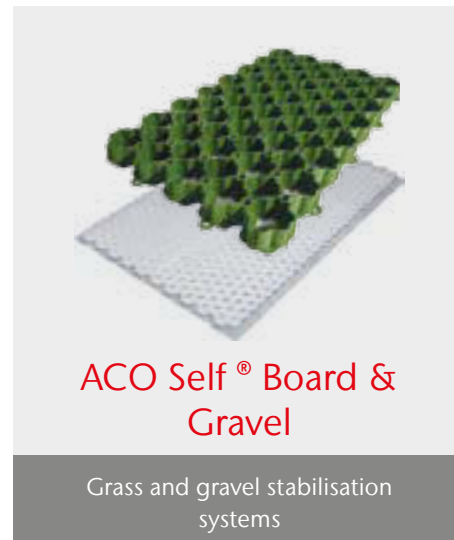





Landscaping

ACO Self[®] Euroline

Polymer concrete drainage channels

ACO Self[®] drainage channels are designed to drain surface rainwater from courtyards and gardens. They combine high quality and design. The gratings can be driven over, and their durability is guaranteed. Available in various designs and materials - cast iron, stainless or galvanized steel, composite or powder coated. The functional range of accessories provides a solution for every situation and easy installation, and ensures trouble-free maintenance.

ACO Self[®] Euroline

Product advantages

- The smooth surface of the polymer concrete and the V-shaped cross section of the channel enhance its hydraulic capacity and self-cleaning performance
- The system can be easily adapted as needed
- The modular system allows designs to meet project requirements
- Large-capacity silt basket
- Designed for a horizontal or vertical DN100 drain
- Modular system per EN1433

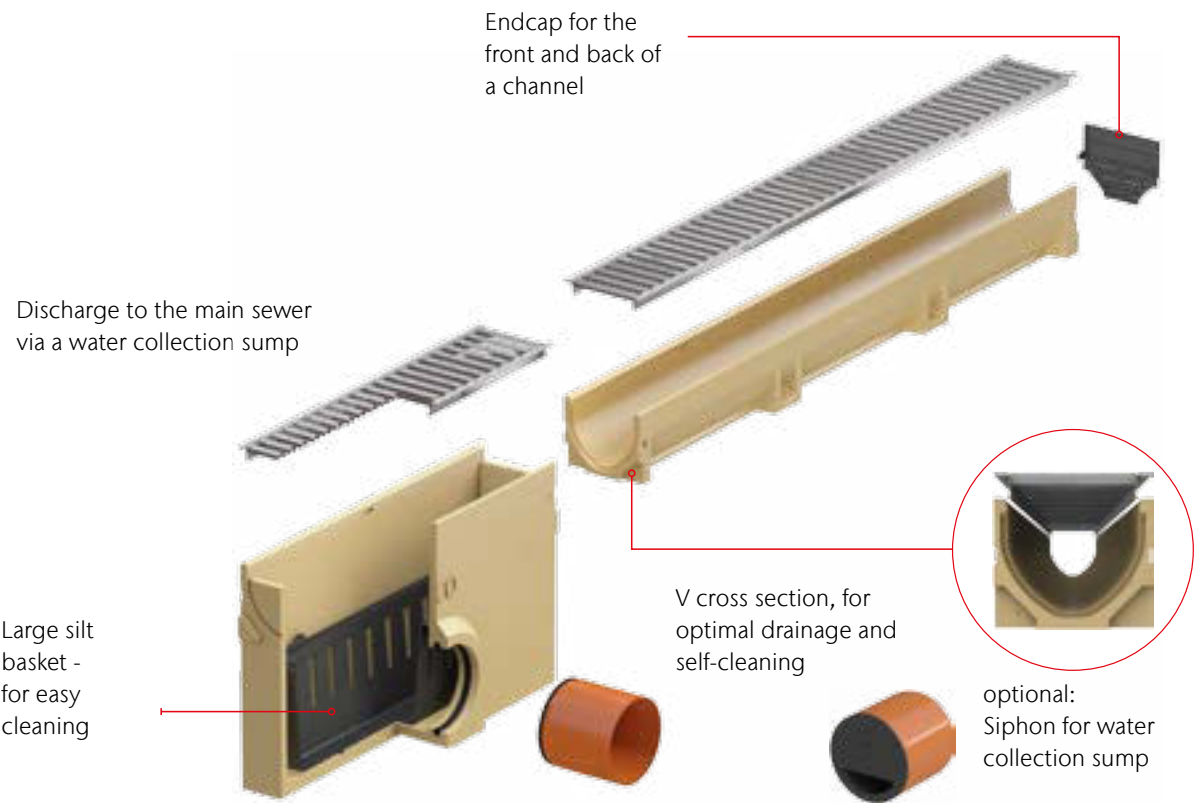

Inspired by the beauty of nature ACO Voronoi designer grating



 red dot winner 2020

- Made in collaboration with the French designer Franck Magné
- May be combined with all ACO Self series channels
- Suitable for gardens, terraces and garage approaches

Discreet slotted grating



- Individual slot designs available, including curved designs
- Variety of slot designs
- Choice of stainless steel or polypropylene (PP)



Flooring - wood



Flooring - stone

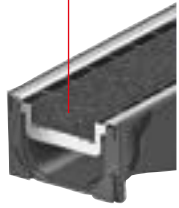

Flooring - Tile

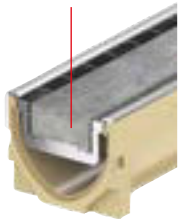

Cast iron grating - Vooronoi







Open areas

ACO Self[®] Board & Gravel

Grass and gravel stabilisation systems

In addition to a wide range of drainage solutions, ACO's product portfolio includes a variety of products that satisfy modern regulations and trends for sustainable design and preservation of natural surfaces that allow water infiltration into the soil.

Soil stabilisation systems are ideal for use in walkways or driveways where natural grass or decorative gravel is required. This prevents the formation of bumps and ruts and prevents damage to soil and plants. At the same time, the surface is stable and even for smooth vehicular and foot traffic.

ACO Self[®] Board

Product advantages

- prevents displacement of pavement, including gravel and soil
- quick and easy installation, thanks to lightweight modular system elements
- stable under light vehicle traffic
- additional accessories: lawn edging and elements for marking parking spaces
- Made of 100% recycled material
- Economical - compared to asphalt and concrete pavements
- UV resistance for longer system life

Pavement layering for green parking:

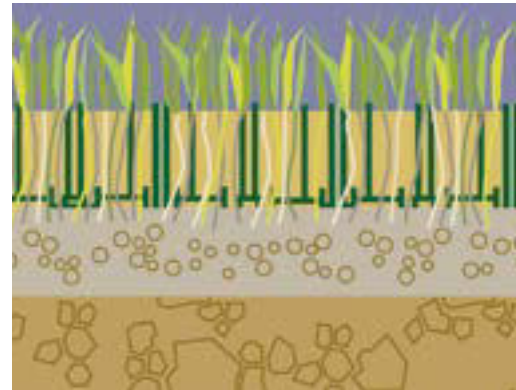

- ACO Board pavement filled with soil
- Fine sand 3-5 cm thick
- Water permeable base layer from 15 to 45 cm (depending on capacity)



Elements for marking parking lots

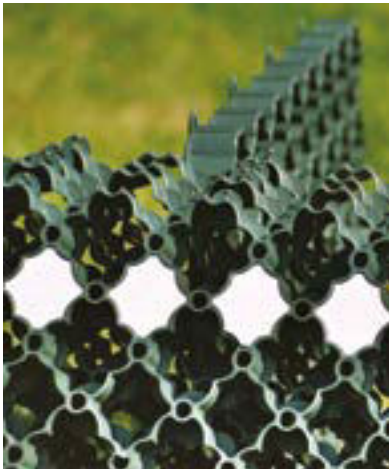

- Edging for lawns - prevents the displacement of pavement or gravel due to temperature differences and dynamic loads from vehicle traffic
- Accessories for landscaping parking - white elements for marking and visual separation of individual grassy areas and parking lots

ACO Self[®] Gravel

Product advantages

- Extremely easy soil reinforcement system
- Eliminates the risk of erosion with frequent use
- Geotextile system that prevents weeds and contributes to easy installation
- Suitable for light vehicle traffic
- Made of 100% polypropylene (PP)



ACO Self[®] restraining profile - for smooth transition between different types of paving materials





Familie Mustermann



Open areas

ACO Vario

Indoor and outdoor shoe scraper for entrances

Shoe scraper for indoor and outdoor use capture coarse dirt, fine dust and moisture and thus aid the maintenance and aesthetic appearance of a building. The ACO Vario series offers standard sizes of shoe scraper for indoor and outdoor use in a variety of materials. They can be easily traversed by wheelchairs and can drain to a sewer system.

ACO Vario

Product advantages

- Pedestrian load class
- Suitable for wheelchairs
- For internal and/or external use
- Possibility for DN100 discharge for a sewer connection
- An inscription of your choice can be added
- Suitable for courtyards and entrances
- Polymer concrete drainage base with a various range of gratings and mats
- Standard sizes - 60/40, 50/75, 100 / 50cm
- Suitable solutions for installation inside and outside abuilding

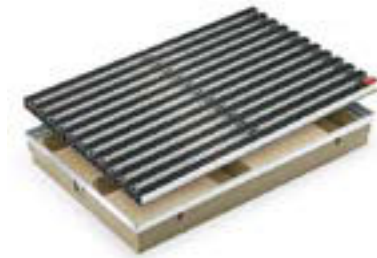

A variety of designs and materials



Rubber insert



Grey ribs insert



Grey ribs with brushes insert



Black ribs insert



Black ribs with brushes insert



Galvanized mesh with 9/31 mm holes

Shoe scraper for outdoor use



Base with galvanized edge



Base of light composite material

Äg

abcdefghijklmnop
qrstuvwxyz äüö
ABCDEFGHIJKLMNÖP
QRSTUVWXYZ ÄÜÖ



We recommend that entrance shoe scraper be designed to meet requirements in three areas - an outer part for larger particles, a rotating gate section and an internal part for fine dust. The characteristics of an entrance shoe scraper are based on the anticipated traffic of people into a building. Our product range includes a variety of professional shoe scraper for entrances that meet all requirements for design, resistance to traffic and load, shapes and sizes.







Open areas

ACO Self[®] Xtra Point

point water drain for courtyards

ACO Self[®] Xtra Point is a courtyard gully that is new to the ACO product range. It is made of durable composite material with a load class of B 125, with included basket for large pieces of trash that has a capacity of 1.1 L. Level placement in pavement is ensured thanks to the modified outer edge of the trap, as well as the low-placed element for anchoring in concrete. The grating can be rotated 90° for easy and rapid installation. The trap has a vertical outlet sized for DN 100

ACO Self[®] Xtra Point

Product advantages

- Bolt-free locking
- Direct positioning in pavement
- Low installation depth
- Large-capacity basket for trash
- No risk of corrosion
- Complete system
- Composite material
- Areas of application: garden, courtyard, light traffic areas

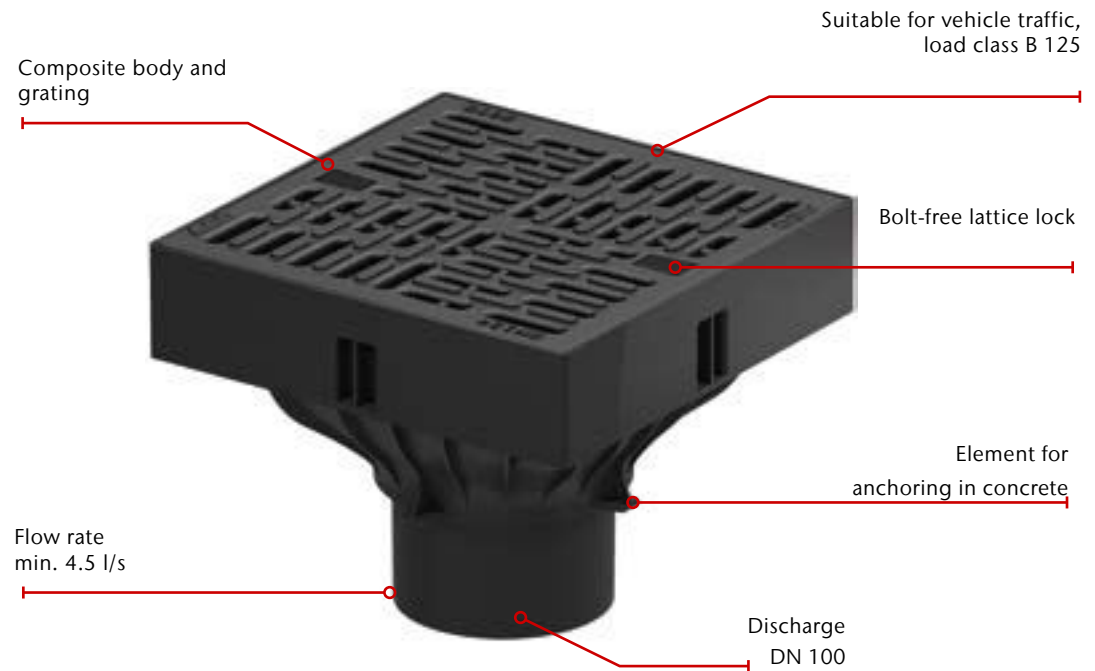

Elements of the system



Main element
250 x 250 x 205



Large trash basket with handle - volume 1.1 l



Grating
-composite material
-galvanized steel

New generation courtyard drainage



The ACO XtraPoint courtyard hully drains rainwater and prevents puddling, satisfying various architectural preferences. Choose between a durable black composite grating or a galvanized steel mesh grating.







Open areas

ACO Uniface Covers

Access covers with embedding of paving materials

All systems and installations remain hidden under the access covers. The structure of the ACO Uniface Covers system allows embedding of flooring in the cover frame. This provides freedom for designing areas with natural stone, paving slabs, asphalt or other architectural solutions without visually interrupting the surface while guaranteeing a smooth surface and stability of the cover, in compliance with European standards.

ACO Uniface Covers

Product advantages

- Variety of materials and heights as required
- Lockable for protection against vandalism and unauthorized access to the shaft
- Manufactured to size on request
- Rubber seal for watertightness and odor containment



C250

Load class D400 for all clear openings of up to 1m

Space for filling with paving stones, natural stone or bituminous filler material to a height of 120 mm



Sturdy welded support elements under the cover

No need for concrete or other structural filler

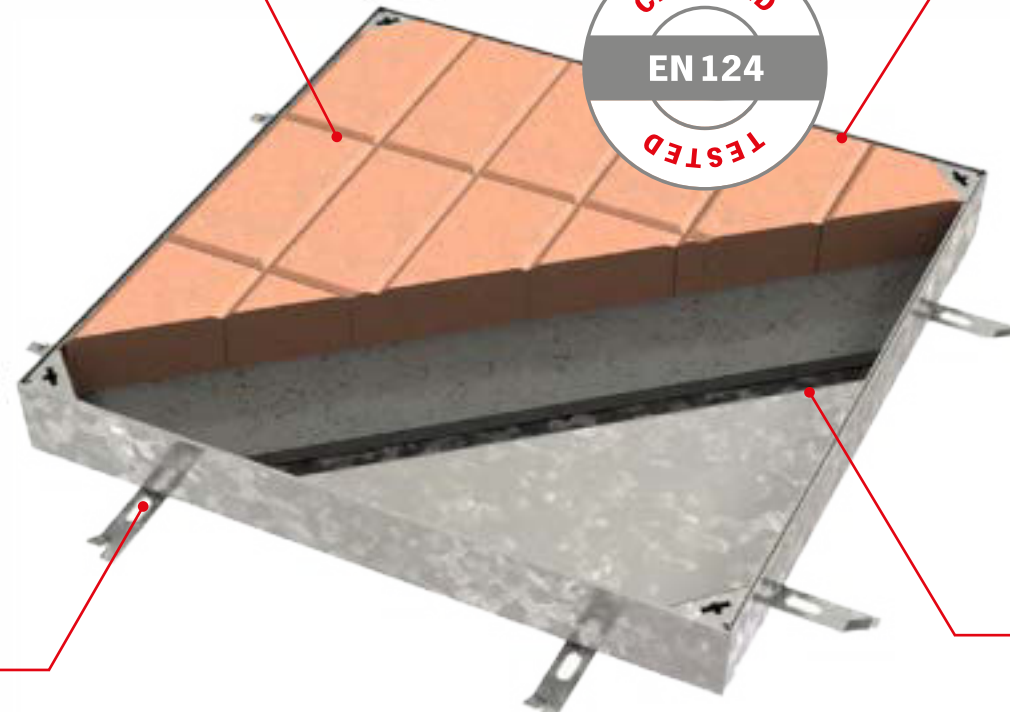



ACO Paving GS



ACO Paving Assist GS

- Option for easy opening system
- Hinges and gas shock absorbers
- Locking with two bolts
- Option for stainless steel version (1.4301 or 1.4571)

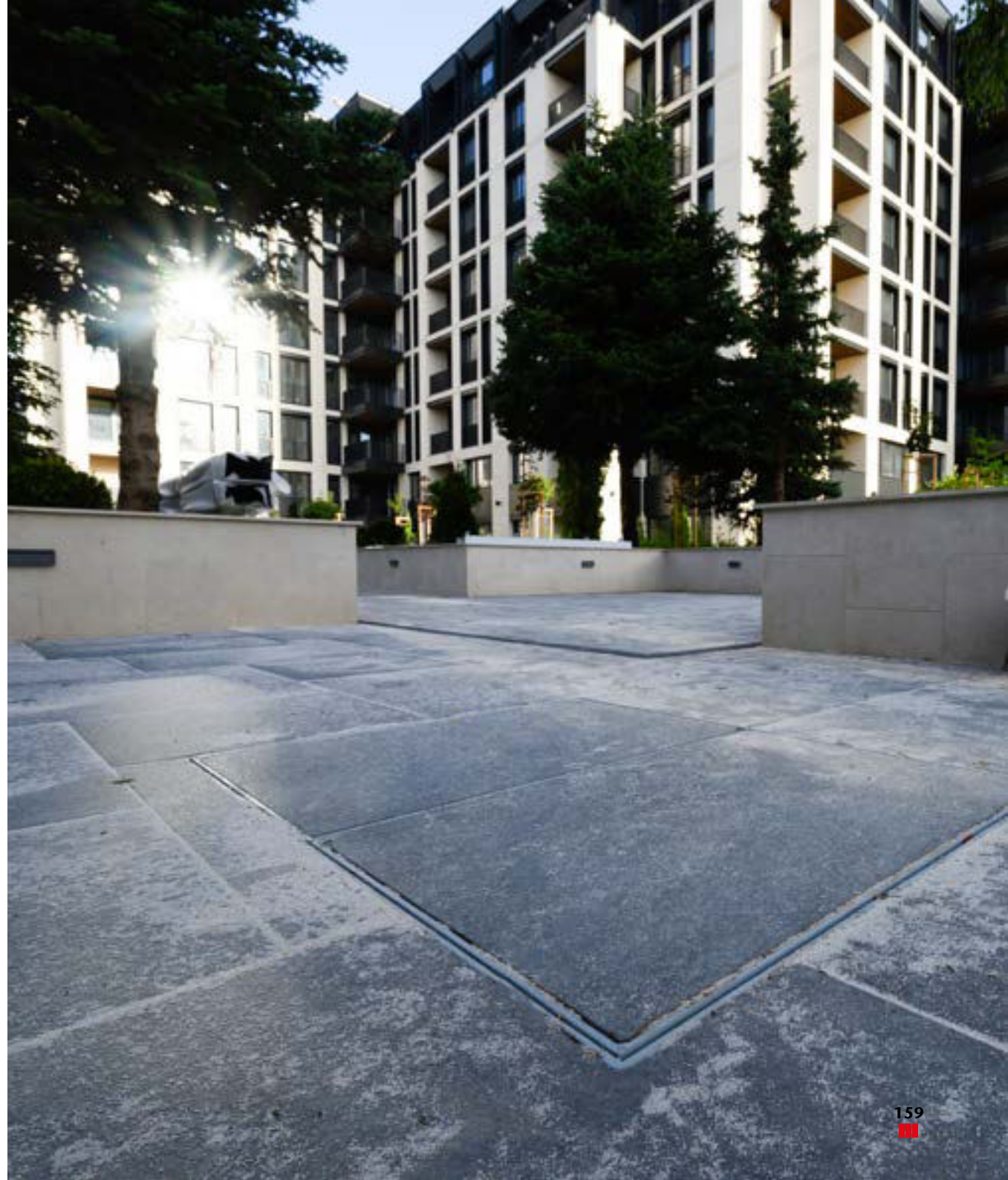

International partnerships and awards:

ACO shares its many years of practical experience through expert participation in several industry and professional organizations and associations.



CEN European Committee for Standardization



British Water, UK



German Institute for Standardization



IWA International Water Association



Plus X Award 2021



Queens Awards for Enterprise Innovation



Iconic Awards



Reddot design award winner 2021 innovative product



Any questions?

askACO

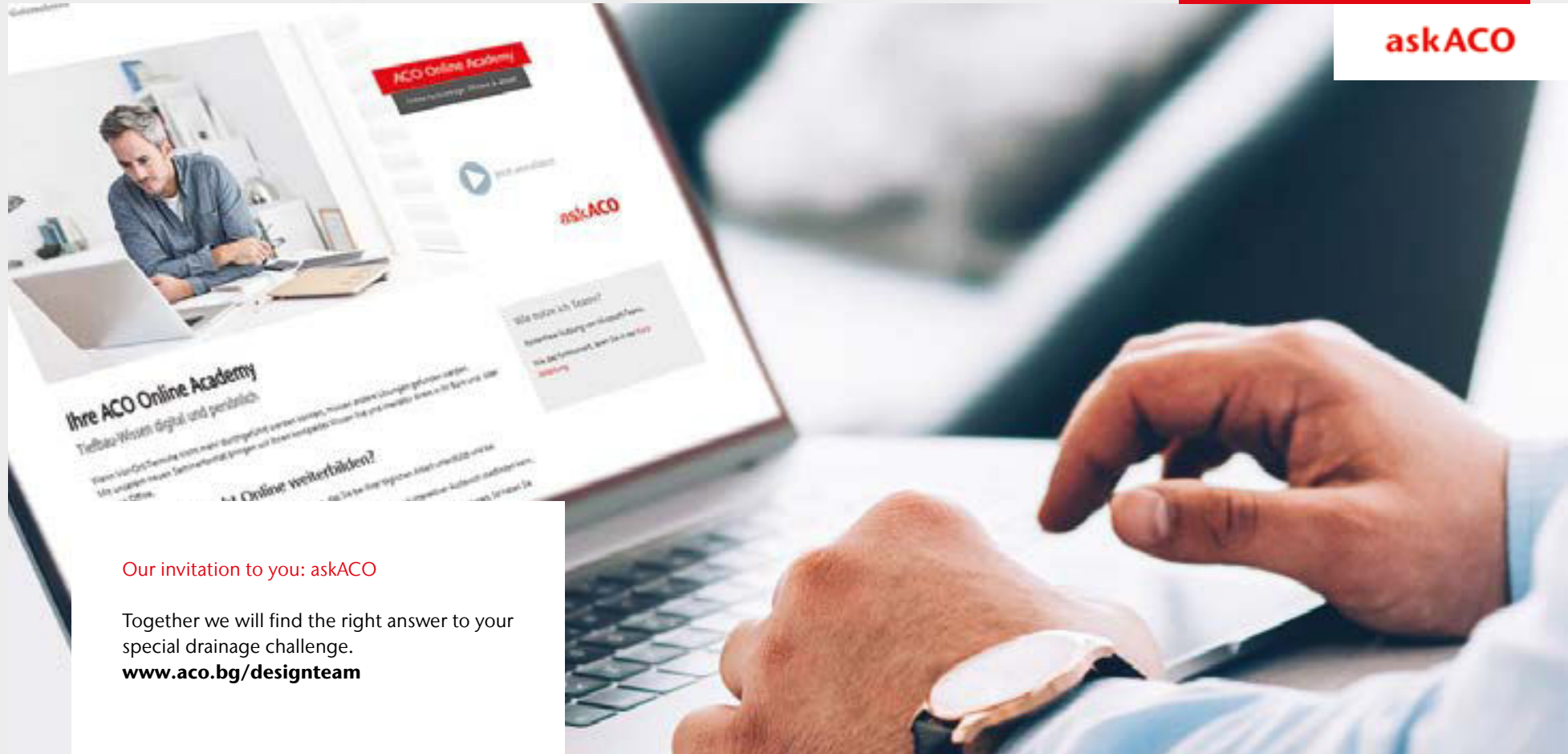

Our invitation to you: askACO

Together we will find the right answer to your special drainage challenge.
www.aco.bg/designteam

ACO Online

Find our products with all important information on the ACO website. Here you will find the technical descriptions, product information, specification texts and installation details you will need during the design planning phase.

www.aco.ro

Welcome to the ACO Academy!

The ACO Academy not only offers up-to-date information with a practical focus, it also focuses on future challenges and opportunities. In addition to events held in the Sofia building, the ACO Academy's annual programme features events across the country to unite the construction industry in its vision "Together for a New Generation of Infrastructure."

Ask your local contact for more information and enrollment in the program
aco@aco.ro