

Detail "A"

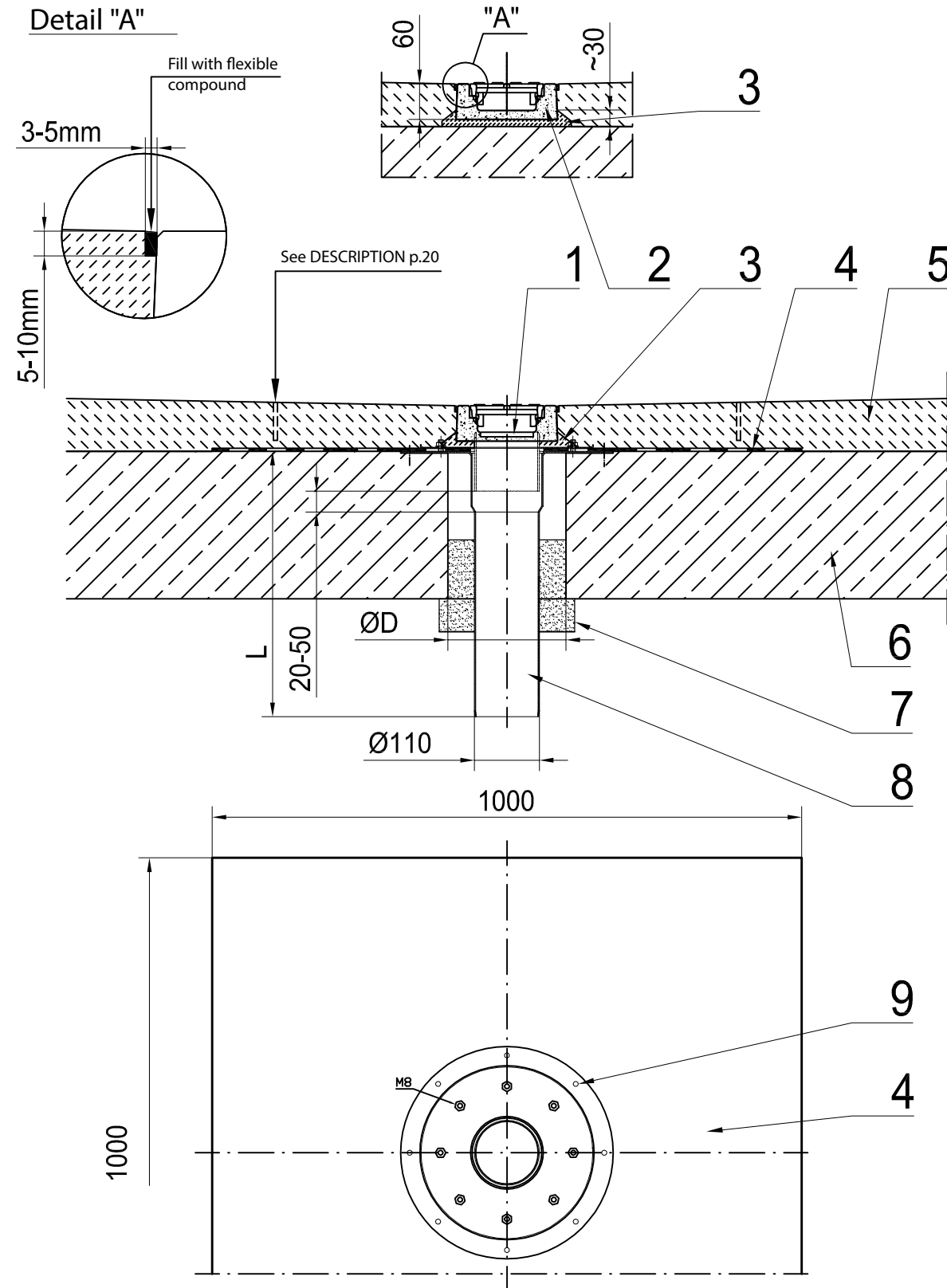

Description of activities

1. Perform an opening in the slab (item 6) at the point of outlet from the ACO channel planned in the water supply and sewerage system design. Dimension "D"=140-200 mm.
2. Fix the tight ACO floor slab penetration element (item 8) with screws (item 9).  
Adjust length "L" to the floor slab (item 6) thickness.
3. Connect the tight penetration element to the pipeline under the floor slab and perform a leakproof test.
4. Perform an insulation of the tight penetration element according to the fire protection (item 7) design.
5. Undo the nuts and remove the press flange and seal from the tight penetration element (item 8).
6. Prepare a 1 x 1 m square sheet of waterproofing membrane (item 4).
7. Clean the surface of the flooring slab and place the waterproofing membrane centrally on the tight penetration element, press and perform openings for screws.
8. Glue the waterproofing membrane sheet to the floor slab starting from the center of the flange of tight penetration element. No blank spots should be found under the waterproofing membrane.
9. Install the seal, press flange and tighten the nuts of the tight penetration element. Cut an opening for an outlet socket.
10. Start laying the ACO Drain channel from trench with outlet (item 1), "L"-shaped connections and "T"-shaped connections.
11. Spread a layer of cement mortar (item 3) on the floor slab along the marked line for laying the ACO trenches. The layer should be approx. 1.5 cm thick and approx. 3 cm wider than the channel width.
12. Press the trench into the mortar and level it. Perform a side shaft of the trench. Note: Hitting the trench directly with a hammer is prohibited. Use an indirect element, e.g. a 2.5 cm thick plank or a plank and a system grating.
13. Prior to installing the last trench glue a closing end cap to it by means of the sealing compound.
14. Seal the trench joints prior to pouring the flooring: Clean, degrease and prime the surfaces of joint grooves between ACO trenches.  
Apply a tight grout according to the manufacturer's manual, fill the groove in the trench.
15. The materials recommended for sealing the joints:  
Sikaflex PRO 3WF and Primer 3N compound manufactured by SIKA Poland Sp. z o. o.  
EUROLASTIC TC30 and EUROLASTIC-Primer S2 compound, supplied by ACO Elementy Budowlane Sp. z o. o.
16. Upon the completion of sealing the trench joints, perform a line leakproof test: blank the channel outlet and fill the channel with water up to its maximum height. The test is qualified as successful if no leak is found within 30 min. from the end of filling of the channel. In case of a leak, improve the sealing and repeat the leakproof test.
17. Provide a waterproofing membrane for joints of walls and structural plate, structural expansion joint grooves and service penetrations in the floor slab. Hydro insulation should be turned up against the walls min. 5 cm above the flooring thickness.
18. Pour the flooring (item 5). The flooring shall be cured properly, in order to minimize its deflection (raising of the flooring edge above the trench edge) by the ACO trench.
19. After the flooring curing process has been completed, seal the joint of trench and flooring with flexible compound. The technology of performance and sealant material – according to the Contractor performing the flooring.
20. In case the deflection of the flooring (raising of the flooring by the ACO trench) exceeds 2 mm perform saw-cut joints parallel to the ACO trench located at the distance of 35-50 cm from the trench. The cut MUST be performed on 0.80-0.90 of the flooring thickness at the cutting point. The groove after cutting shall be sealed with permanently flexible compound.
21. After finishing the pavement, clean the bottom of the ACO channel and install the gratings.

List of elements

Item	Description of the drawing on page 1
1	ACO Drain P100 low channel, h = 6 cm, trench with outlet Ø110
2	ACO Drain P100 low channel, h = 6 cm,
3	M15 cement mortar
4	Waterproofing membrane 1x1 m to be glued
5	Flooring, sloping layer, concrete finishing acc. to the design
6	Floor slab
7	Insulation of the pipeline according to the fire protection design
8	Tight ACO Drain Ø110 floor slab penetration element, length adjusted to the floor slab thickness
9	5.5 screw with wall plug - 3 pcs.

Note

ACO delivery includes only items No. 1, No. 2 and No. 8.

Drawing title Installation manual for ACO P100 parking channel to be installed in a floor slab over an underground garage. Concrete flooring.	Standard PN-EN 1433:2005	ACO DRAIN system <b>P100 with the height of h=6 cm</b>
	Load class A15 - C250 In compliance with the conditions of ACO installation manuals	ACO Elementy Budowlane Sp. z o. o. Łojski, ul. Fabryczna 5 Phone: 0-48 22 76 70 500 05-119 Legionowo Fax: 0-48 22 76 70 513
Technical changes reserved	2016-01-26	Page 2 / 2
The declaration of conformity available on www.aco.pl		

Drawing title Installation manual for ACO P100 parking channel to be installed in a floor slab over an underground garage. Concrete flooring.	Standard PN-EN 1433:2005	ACO DRAIN system <b>P100 with the height of h=6 cm</b>
	Load class A15 - C250 In compliance with the conditions of ACO installation manuals	ACO Elementy Budowlane Sp. z o. o. Łojski, ul. Fabryczna 5 Phone: 0-48 22 76 70 500 05-119 Legionowo Fax: 0-48 22 76 70 513
Technical changes reserved	2016-01-26	Page 2 / 2
The declaration of conformity available on www.aco.pl		